

SBA



BORDERLESS
NETWORKS



DESIGN
OVERVIEW

Panduit Facilities and LAN Access Layer Physical Infrastructure Reference Guide



● ● ● SMART BUSINESS ARCHITECTURE

February 2013 Series

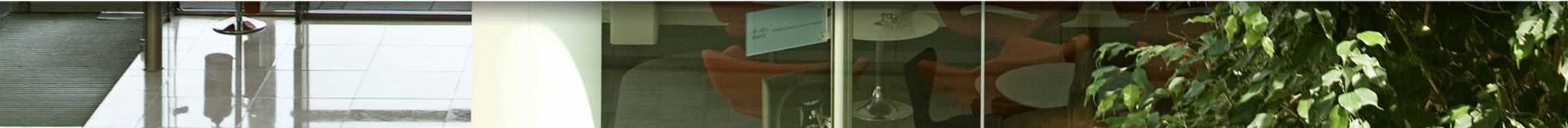

Preface

Who Should Read This Guide

This Cisco® Smart Business Architecture (SBA) guide is for people who fill a variety of roles:

- Systems engineers who need standard procedures for implementing solutions
- Project managers who create statements of work for Cisco SBA implementations
- Sales partners who sell new technology or who create implementation documentation
- Trainers who need material for classroom instruction or on-the-job training

In general, you can also use Cisco SBA guides to improve consistency among engineers and deployments, as well as to improve scoping and costing of deployment jobs.

Release Series

Cisco strives to update and enhance SBA guides on a regular basis. As we develop a series of SBA guides, we test them together, as a complete system. To ensure the mutual compatibility of designs in Cisco SBA guides, you should use guides that belong to the same series.

The Release Notes for a series provides a summary of additions and changes made in the series.

All Cisco SBA guides include the series name on the cover and at the bottom left of each page. We name the series for the month and year that we release them, as follows:

month year Series

For example, the series of guides that we released in February 2013 is the “February Series”.

You can find the most recent series of SBA guides at the following sites:

Customer access: <http://www.cisco.com/go/sba>

Partner access: <http://www.cisco.com/go/sbachannel>

How to Read Commands

Many Cisco SBA guides provide specific details about how to configure Cisco network devices that run Cisco IOS, Cisco NX-OS, or other operating systems that you configure at a command-line interface (CLI). This section describes the conventions used to specify commands that you must enter.

Commands to enter at a CLI appear as follows:

```
configure terminal
```

Commands that specify a value for a variable appear as follows:

```
ntp server 10.10.48.17
```

Commands with variables that you must define appear as follows:

```
class-map [highest class name]
```

Commands shown in an interactive example, such as a script or when the command prompt is included, appear as follows:

```
Router# enable
```

Long commands that line wrap are underlined. Enter them as one command:

```
wrr-queue random-detect max-threshold 1 100 100 100 100 100  
100 100 100
```

Noteworthy parts of system output or device configuration files appear highlighted, as follows:

```
interface Vlan64  
ip address 10.5.204.5 255.255.255.0
```

Comments and Questions

If you would like to comment on a guide or ask questions, please use the [SBA feedback form](#).

If you would like to be notified when new comments are posted, an RSS feed is available from the SBA customer and partner pages.

Table of Contents

| | | | |
|---|----------|--|-----------|
| What's In This SBA Guide | 1 | LAN Access Network Cabling | 14 |
| Cisco SBA Borderless Networks..... | 1 | Panduit Fiber Cabling Solutions | 14 |
| Route to Success | 1 | Panduit Copper Cabling Solutions..... | 15 |
| About This Guide | 1 | Telecommunications Room Deployment | 17 |
| Introduction | 2 | Zone Cabling Architectures..... | 25 |
| Related Reading | 2 | Consolidation Points..... | 26 |
| Business Overview | 3 | TR-to-Work-Area Pathways | 30 |
| Architecture Overview | 4 | Endpoints..... | 35 |
| Overall Building Floor Plan | 4 | Additional Physical Infrastructure Elements..... | 35 |
| Smart Business Architecture LAN Design | 7 | Appendix A: Bill of Materials | 45 |
| Alignment of Logical Architecture to Physical Infrastructure | 9 | Appendix B: References | 50 |
| Telecommunication Rooms (TR) | 9 | About Panduit | 51 |
| | | Disclaimer | 51 |

What's In This SBA Guide

Cisco SBA Borderless Networks

Cisco SBA helps you design and quickly deploy a full-service business network. A Cisco SBA deployment is prescriptive, out-of-the-box, scalable, and flexible.

Cisco SBA incorporates LAN, WAN, wireless, security, data center, application optimization, and unified communication technologies—tested together as a complete system. This component-level approach simplifies system integration of multiple technologies, allowing you to select solutions that solve your organization's problems—without worrying about the technical complexity.

Cisco SBA Borderless Networks is a comprehensive network design targeted at organizations with up to 10,000 connected users. The SBA Borderless Network architecture incorporates wired and wireless local area network (LAN) access, wide-area network (WAN) connectivity, WAN application optimization, and Internet edge security infrastructure.

Route to Success

To ensure your success when implementing the designs in this guide, you should first read any guides that this guide depends upon—shown to the left of this guide on the route below. As you read this guide, specific prerequisites are cited where they are applicable.

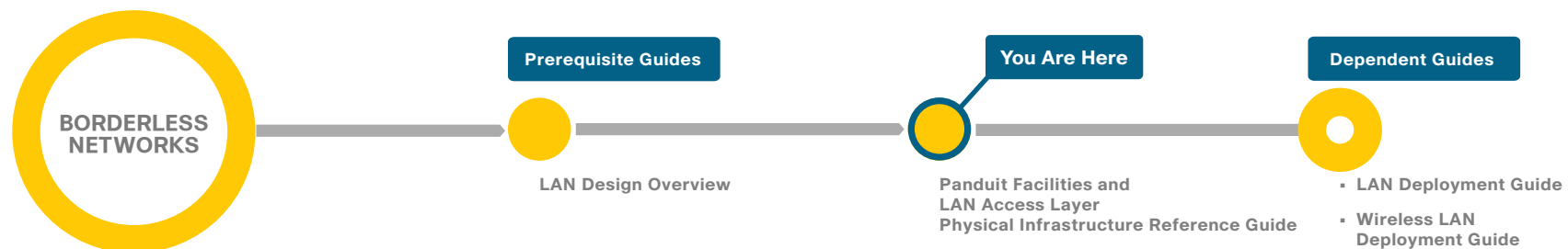

About This Guide

This *ecosystem partner guide* presents solutions, products, or services—provided by a Cisco SBA ecosystem partner—that are compatible with and complementary to SBA.

You can find the most recent series of Cisco SBA guides at the following sites:

Customer access: <http://www.cisco.com/go/sba>

Partner access: <http://www.cisco.com/go/sbachannel>

Introduction

The Cisco Smart Business Architecture (SBA) is a comprehensive design that incorporates LAN, WAN, security, application optimization, data center, and unified communications technologies to provide a complete solution for an organization's business challenges. The Cisco SBA—Borderless Network LAN design incorporates network access for wired and wireless users, ranging from small remote sites with a few connected users to large locations with up to 5,000 connected users. The *Cisco SBA—Borderless Networks LAN Deployment Guide* is a set of prescriptive, out-of-the-box deployment guides that is based on best-practice design principles and delivers flexibility and scalability.

The *Panduit Facilities and LAN Access Layer Physical Infrastructure Reference Guide* provides a comprehensive solution to building a solid LAN foundation for your organization. This guide goes beyond addressing the aspects of copper and fiber optic cabling for user access by including:

- System integration for building management
- Secured access to sensitive locations
- Power and cooling considerations for the facility

The Cisco SBA LAN design provides the foundation network connectivity for users, printers, WAN routers, security, and all of the other devices that connect users to the applications they require to do their job. Resiliency, security, and scalability are included to provide a robust communications environment. Quality of service (QoS) is integrated to ensure that the base architecture can support a multitude of applications including low latency and drop-sensitive multimedia applications coexisting with data applications on a single network. The *Wireless LAN Deployment Guide* provides a guest and partner access solution that is secured from accessing internal confidential information while using the same wireless infrastructure that employees use.

The recommended products and design in the *Panduit Facilities and LAN Access Layer Physical Infrastructure Reference Guide* focus on the requirements of the Cisco SBA LAN design to address the physical and environmental requirements of building a solid network foundation for your organization.

Related Reading

The *Cisco SBA—Borderless Networks LAN Design Overview* familiarizes you with the overall Cisco SBA design for wired and wireless connectivity, and explains the requirements that were considered when selecting specific products.

The *Cisco SBA—Borderless Networks LAN Deployment Guide* describes how to deploy a wired network access with abundant capabilities that scale from small environments with one to a few LAN switches to a large campus-size LAN. Resiliency, security, and scalability are included to provide a robust communications environment. QoS is integrated to ensure that the base architecture can support a multitude of applications including low latency, drop-sensitive multimedia applications that coexist with data applications on a single network.

The *Cisco SBA—Borderless Networks Wireless LAN Deployment Guide* focuses on deploying the Cisco Unified Wireless Network in multiple network locations and includes multiple scale models to meet the various LAN deployment sizes. The deployment guide uses a controller-based wireless design. By centralizing configuration and control on a Cisco wireless LAN controller (WLC), the wireless LAN can operate as an intelligent information network and support advanced services. This centralized deployment simplifies operational management by collapsing large numbers of managed endpoints and autonomous access points into a single managed system.

Business Overview

We created this guide to supplement the *Cisco SBA—Borderless Networks LAN Design Overview* and *LAN Deployment Guide*. The *LAN Design Overview* addresses five primary requirements shared by organizations, including the need to:

- Offer reliable access to organization resources
- Minimize time required to absorb technology investments
- Allow workforce mobility
- Provide guest access
- Reduce operation costs

To help address these requirements on the physical layer, Panduit leverages a Unified Physical InfrastructureSM (UPI) approach. These end-to-end UPI solutions exist across information technology, manufacturing operations, and building management systems and are able to connect, manage, and automate all critical systems. By employing the UPI approach across core business systems, including communication, computing, control, power, and security, organizations can increase business agility and sustainability while lowering risk and cost.

This *Panduit Facilities and LAN Access Layer Physical Infrastructure Reference Guide* seeks to extend the value of the *LAN Deployment Guide* by:

- Demonstrating how facilities and information technology (IT) stakeholders can integrate a UPI-based connected building solution into the client access layer of the Cisco SBA LAN architecture.
- Providing a concrete example of how the logical architecture maps to Panduit physical infrastructure capabilities within the organization to deliver the key design goals of the Cisco SBA program.

This guide offers direction to organizations designing all aspects of the physical infrastructure of a Cisco SBA LAN deployment including:

- Cabinets and racks
- Overhead and under-floor pathways
- Copper and fiber optic cabling
- Cable routing and management
- Grounding and bonding
- Identification
- Physical infrastructure manager

Architecture Overview

Before you examine the physical infrastructure design elements in more detail, you should analyze the logical architectures of the *Cisco SBA—Borderless Networks LAN Deployment Guide* and those involved with a UPI-based solution. Building implementations based on the UPI approach can vary widely in scope and complexity. In addition to considering size, you need to select technology vendors and partners that offer comprehensive suites of products, software, and services that meet business requirements.

The modular architecture developed in the *LAN Deployment Guide* is the perfect foundation for deploying a network solution on a single infrastructure hosting data, voice, video, and wireless technologies as well as other applications such as building automation systems (BAS). This guide provides certain assumptions and constraints to offer the necessary context and clarity around the physical solution. By focusing on a single example scenario, it is easier for IT and facilities stakeholders to reach a consensus on a common solution baseline and to analyze the elements of the design in greater depth. This gives them more concrete guidance and fosters cooperation between constituencies with traditionally different points of view.

The reference architecture described in this document can be best demonstrated with a leading edge organization example. The model organization used in this guide is the world headquarters for a leading networking infrastructure manufacturer. The example uses a single green field site, i.e. not a campus, and has four floors. Most of the ground floor is allocated to the enterprise data center, meeting rooms, demonstration areas, training rooms, cafeteria space, etc., so the staff occupies work areas in floors two through four. Each of these three floors has an area of approximately 44,000 square feet and supports approximately 220 employees in work stations and offices. The building network supports areas such as lighting, heating, ventilation and air conditioning (HVAC), energy management, access control, and video surveillance among others on the Ethernet network. Existing internal facilities personnel are responsible for maintaining the newly deployed system.

Assumptions and constraints are also summarized by principles that provide governance for the overall design. Whenever possible, rationale and the implications of following these principles are also offered. This guide is not meant to be an exhaustive list of design principles, but it provides several ideas that stimulate further conversation between network architects and management that will ultimately sponsor a project of this nature.

Overall Building Floor Plan

In order to give a clear understanding of the UPI approach to physical infrastructure design, a specific floor plan and actual technologies from Panduit and other partners are presented in this reference guide. Though no two buildings are constructed exactly alike, the example layout presented here can act as a foundation for further design discussions between IT and facilities. The principles and concepts illustrated here are completely reusable in a wide array of use cases and should be considered best practices in enterprise deployments. It is expected that readers will leverage the appropriate professional services organizations to take this example and tailor it to their specific organizational context.

Figure 1 illustrates the reference building used as the basis for discussion throughout this document.

Figure 1 - Reference building schematic

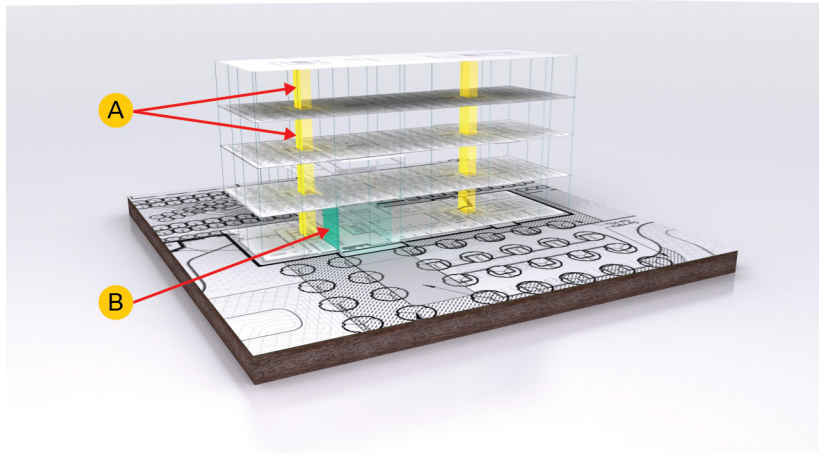

- A** Telecom Room (TR)
- B** Data Center

Figure 2 shows a schematic of the location of the telecommunication rooms (TRs) within the reference building. For clarity, only two floors are shown. The schematic shows a typical backbone structure providing main data runs (green lines) from the data center to the TRs on each side of the building. In addition, to support a high availability design securing and protecting critical data needs, alternate path fiber runs (red lines) are routed to each TR through the opposite riser, then through the opposite TR, and then run horizontally to the supported TR. The TRs provide a secure environment for active equipment and passive termination points for all user endpoints and any included BAS equipment. Both overhead and underfloor pathways are installed in this reference design to allow more flexibility in endpoint device placement and cable management. In addition to pathways in the overhead and underfloor spaces, zone enclosures provide consolidation points that eliminate the need for long cabling homeruns back to TRs and the data center. All of these elements are covered in more depth throughout this document.

Figure 2 - Schematic arrangement for telecom rooms on two floors

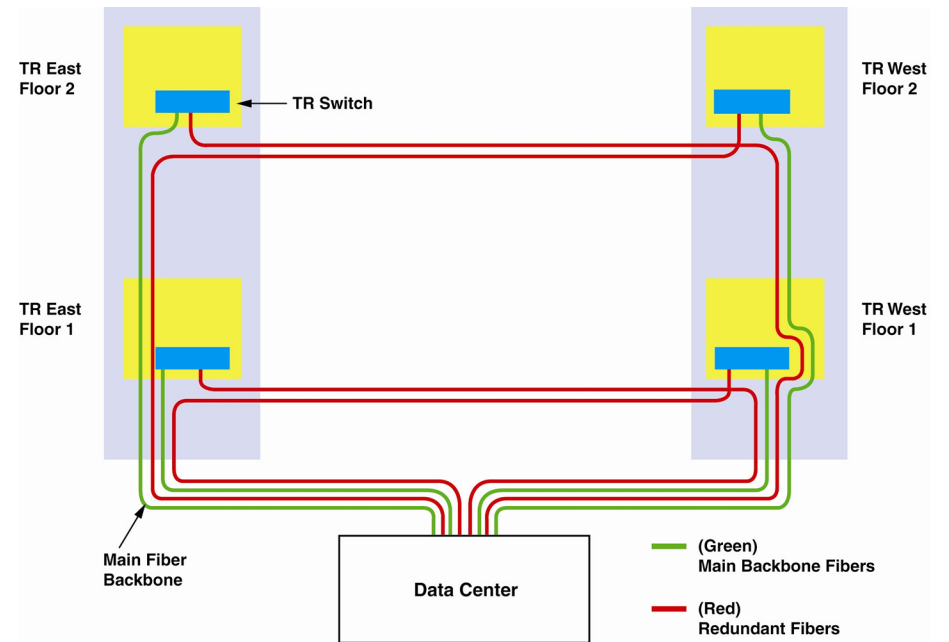

There are a variety of benefits and challenges associated with the decision to install both a drop ceiling and raised floor in this reference design. Raised floor installations offer the benefit of an additional space for running large volumes of cabling to devices such as IP phones and workstations, which are located closer to the floor. In addition, raised floors contribute to a more sustainable environment by allowing greater flexibility in air flow delivery to the various workspaces and offices throughout the building. However, this increased flexibility and space come at a cost premium and are not necessarily advantageous if there are lower cable counts or if airflow is not a particular challenge in the building. The drop ceiling is utilized for cable routing and management—particularly for devices such as IP cameras, physical access gateways, and lighting components mounted in the ceiling or against office walls.

This document focuses on the LAN access layer client connectivity of the organization, typically the part of the network outside of the data center. Therefore, it includes the TR, pathway solutions, and work areas. An examination of the first floor, including the data center, is beyond the scope of this document. For a more in-depth discussion of data center design, see Panduit's UPI-based reference designs for optimized, intelligent data centers described in the *Panduit Network Core and Data Center Physical Infrastructure Reference Guide*.

The following table makes a number of assumptions about the active equipment on each floor (second through fourth floors only).

Table 1 - Assumptions for second through fourth floors

| IT requirement | Assumed value |
|--|---|
| Number of employees hosted on each floor | 220 |
| Number of network connections per employee | 1 for IP phone (PCs and laptops then plug into the phone) |
| Additional IT devices (printers, training room PCs, hoteling stations, etc.) | 100 |
| IP-based BAS devices (IP surveillance cameras, physical security, etc.) | 100 |
| BAS devices connected via fieldbus cabling to controller communications bus | 100 |

Noting that per the TIA-568-C standards, each work area outlet is provided with two structured cable runs, and then each floor could potentially require up to approximately 800 access layer switch downlink ports, i.e. $2 \times \text{No. of employees} + 2 \times \text{No. IT devices} + 1.5 \times \text{No. IP BAS devices} = 2 \times 220 + 2 \times 100 + 1.5 \times 100 = \sim 800$.

The 1.5 figure is used for the IP BAS devices, since not all devices were supplied with two cables. Four Cisco 4507R+E switches, each supporting $240 \times 10/100/1000$ downlink ports were used for the access layer switching, using two of these in each of the TRs, with two TRs per floor. Note that not all switch ports are used in this deployment, thereby giving expansion capability should it be required in the future.

Notes

Smart Business Architecture LAN Design

Connecting disparate facilities systems with an organization's IT networks is the first step in realizing a truly intelligent building. This is referred to as IP convergence, or the transmission of different types of traffic over a single network using the Internet Protocol (IP). IP convergence initially became popular for running voice, video, and data over the same network to simplify management, increase flexibility, and lower costs. In modern organizations, industrial automation and building systems are being deployed using the IP network to drive these benefits even further. The *Cisco SBA—Borderless Networks LAN Design Overview* provides the necessary foundation for IP convergence. Figure 3 illustrates the Cisco SBA LAN design that supports the networking needs of the reference building described in this guide.

Figure 3 - Cisco SBA LAN design overview

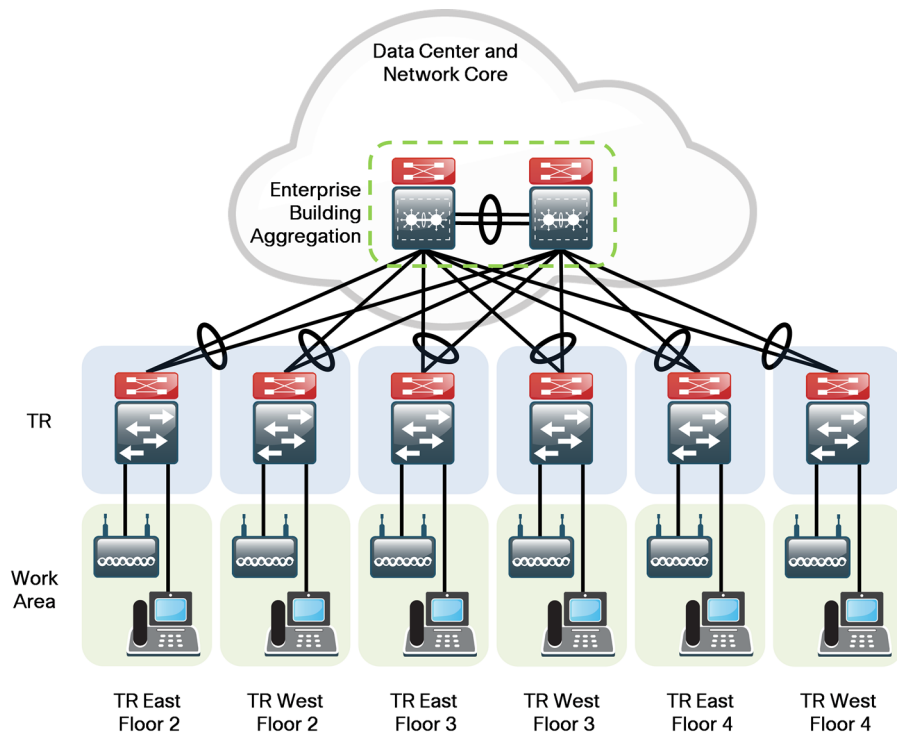

Of particular interest to an organization's effort is the access layer of the solution, which is depicted in Figure 4. The access layer is the point at which user-controlled and user-accessible devices like IP phones and laptops are connected to the network. The access layer provides both wired and wireless connectivity via wireless access points and contains features and services that ensure security and resiliency for the entire network. BAS elements should also converge logically and physically at this layer of the design.

Figure 4 - Access layer overview

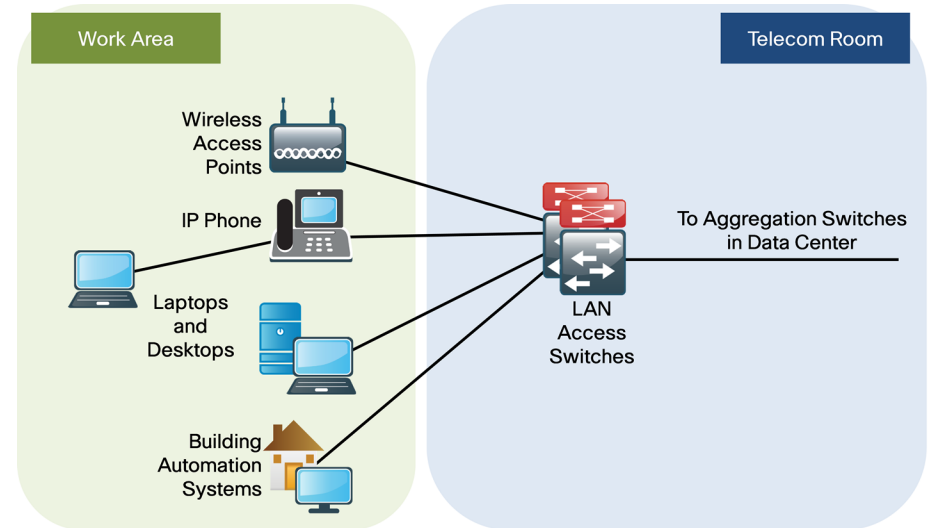

The logical integration between building systems and the IT organization begins with the proper selection of connectivity, communications protocols, and Power over Ethernet (PoE). Then, security zones can be configured to control the flow of information between these integrated systems to reduce risk. These zones can be created by hosting BAS elements on their own virtual local area networks (VLANs) and enforcing policies on network traffic that traverses these VLANs using access control lists (ACL) or firewall technology.

Once connectivity is established, data can be collected and correlated by the appropriate software platforms to enable policy-based management of the building automation system. These systems could then roll up into an enterprise management platform that presents a complete, holistic view of all logical and physical elements in the organization through a single view of the laptop screen. In addition to management systems, networking could be implemented for accommodating organizations with multiple sites, safely allowing remote management of the BAS, and for securely interacting with power utility smart grids and other external entities over the Internet.

Notes

Alignment of Logical Architecture to Physical Infrastructure

After understanding the Cisco SBA LAN design and connected building logical architectures, the next step in the Panduit UPI approach is to map the logical architectures to a converged physical infrastructure throughout the building. With a complete understanding of the logical architectures involved in this design, smart decisions can be made about product selection and placement to provide maximum availability, agility, sustainability, and cost effectiveness. In addition, IT and facilities stakeholders can have confidence that the physical infrastructure gets deployed in a way that optimizes power, cooling, space, speed, and performance throughout the organization. Additional benefits can be realized in enterprise installation costs by installing a common cable for both IT and BAS networks.

The concept of physical and logical convergence within the enterprise is often challenging to stakeholders from different departments. For example, IT and Facilities personnel may object to co-hosting building automation system appliances and IT devices within shared telecommunications rooms. This is why the Telecommunication Rooms (TR) section stresses security related to physical convergence and offers recommendations to reduce risk.

This document reviews the key elements of the physical design of the networking infrastructure deployed in the enterprise including the TR, zone cabling architecture, and endpoint mounting.

Telecommunication Rooms (TR)

The telecommunications room (TR) is a horizontal zone consolidation point, and is a vital point of aggregation for a series of network and building control systems. The TR also functions as the point of physical convergence for field level supervisory BAS components and network elements. For this reference design, the TR enables the integration of control systems noted previously. Security is of paramount importance within these spaces because organization technicians with differing roles need to access the components at different times. As a result, employee access to these spaces and equipment has to be dependent on and is determined by their particular role in the organization.

The end result of a TR is a consolidated and organized environment for floor level active equipment that optimizes space and provides floor level control of assets. The TR is designed to build flexibility and scalability into the building physical infrastructure and should be designed to accommodate future BAS and network growth, including additional controllers, patch fields, and networking equipment. TRs may also need to house server and storage equipment related to IT and BAS functions, as in the case of multi-tenant facilities. In this case, special attention needs to be given to power and cooling requirements.

Figure 5 shows an overhead view of the standardized TRs throughout this guide's reference building. In this building example, two TRs exist on every floor of the building, providing a secure space for active and passive infrastructure equipment. The rooms measure approximately 12 ft. x 14 ft. (3.6 m x 4.3 m) totaling 168 ft² (15.6 m²), which is an acceptable footprint according to the TIA-569-B standard for TR design. The primary elements of the room include electrical panels for power distribution, the Telecommunications Grounding Busbar (TGB), four post rack systems with passive and active infrastructure components, and a backbone conduit. The figure shows the mapping of the logical architectures to these physical elements in the TR.

- A** Telecommunications grounding busbar (TGB)
- B** Electrical panels
- C** Conduit for backbone cabling back to data center
- D** Panduit® 4 Post Rack Systems

Figure 5 - Mapping the Logical Architecture to the TR

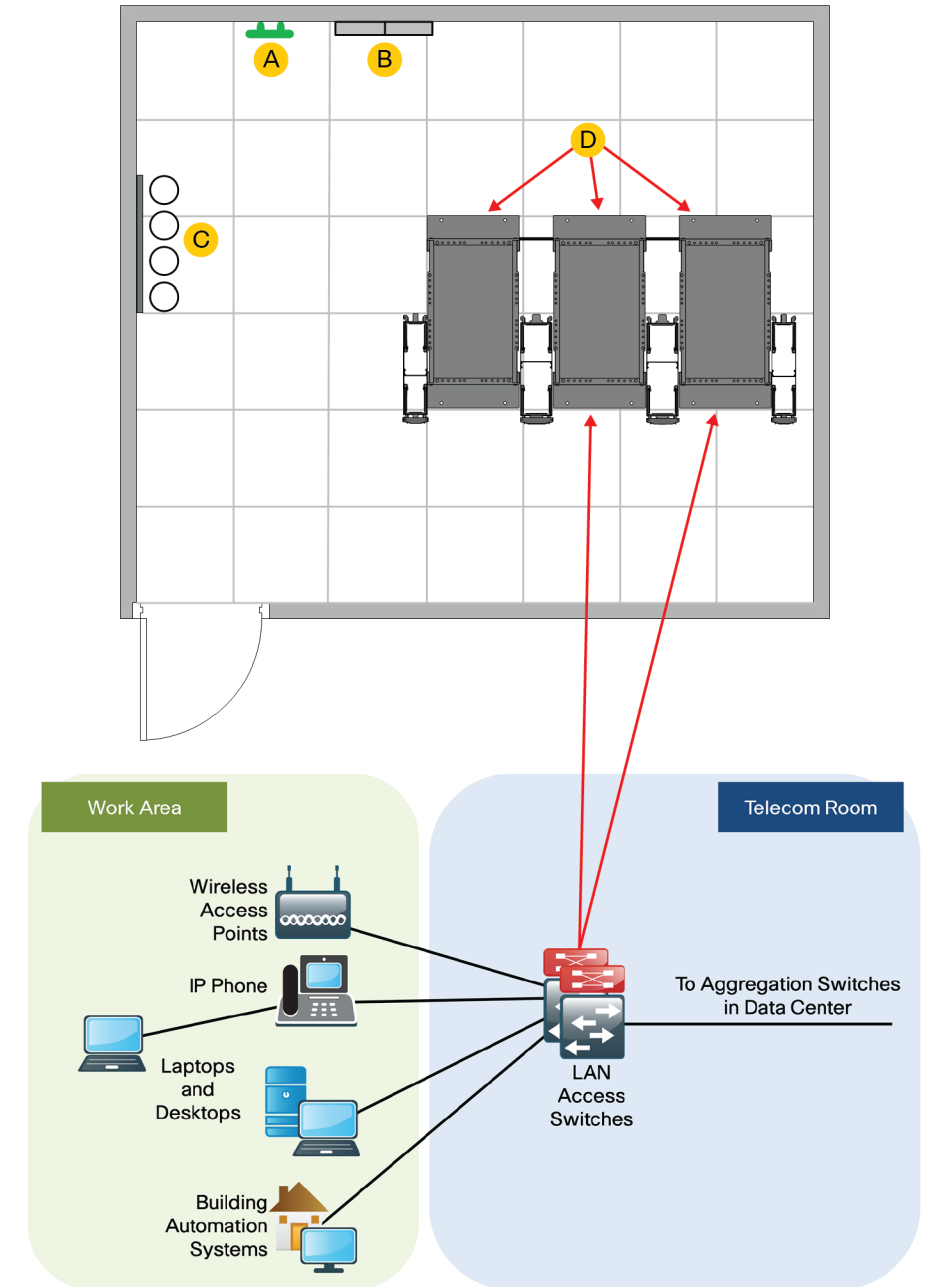
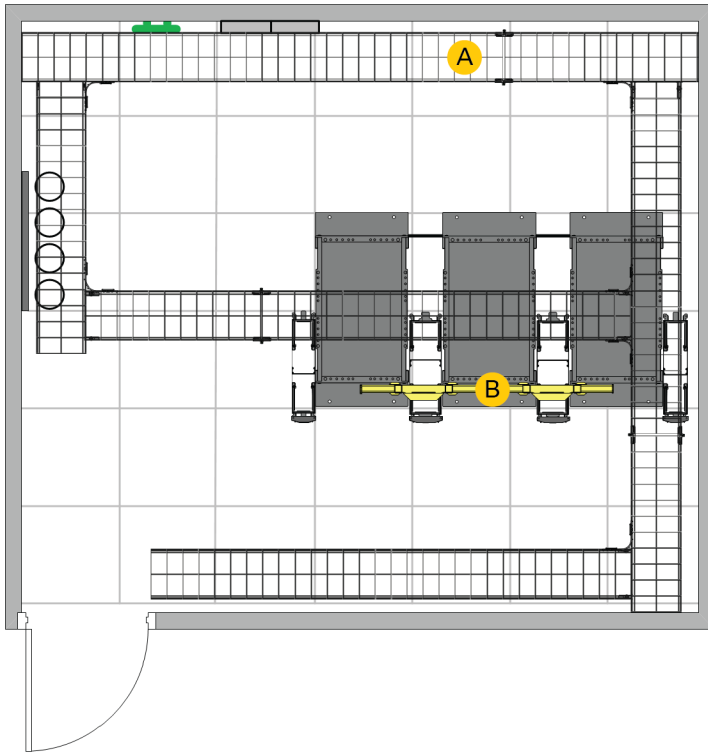
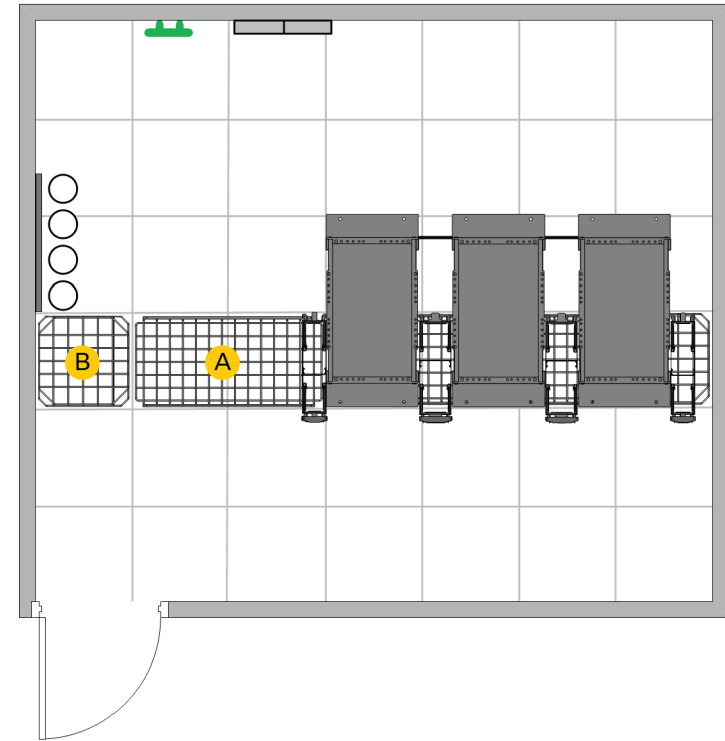

Figure 6 - Overhead pathways within the TR



- A** Wyr-Grid® Pathway Section - 12 in. (305 mm) width, utilizing optional 4 in. (102 mm) sidewalls
- B** FiberRunner® Pathway System - 2 in. x 2 in. (50.8 mm x 50.8 mm)

Figure 7 - Underfloor pathways within the TR



- A** GridRunner™ System – 21 in. x 4 in. x 48 in. (533 mm x 100 mm x 1219 mm)
- B** GridRunner™ Universal Intersection – 22.62 in. x 22.62 in. (575 mm x 575 mm)

Figures 6 and 7 show the overhead and underfloor pathways found in the TRs. These structures provide robust and modular pathways through which bulk cabling can be effectively routed within the TRs, between the TRs and the data center, and between the TRs and zone enclosures throughout the building. Copper cabling is routed overhead via the Panduit® Wyr-Grid® Cable Tray System and under the raised floor via the GridRunner™ Underfloor Cable Routing System. Because about 75% of the copper cabling that leaves the TR is routed through the GridRunner™ System to end-user devices, designers must give special attention to appropriately sizing the GridRunner™ pathway channels.

Fiber optic cabling is only routed overhead in the Wyr-Grid® System and FiberRunner® Routing System. The two pathway systems are used for different deployment examples of fiber cable. The riser fibers used in the reference building described in this guide are armored Opti-Core® OM3 Riser Distribution Cable and are installed directly onto the Wyr-Grid® System. In the facility example described in this reference guide, these armored fiber cables are used to provide redundancy within the network and connect the two TRs on each floor. Panduit® Opti-Core® LC to LC 10 Gig™ OM3 Multimode Duplex patch cords enable data communications between racks or cabinets and are routed in the FiberRunner® Routing System, which provides adequate support and protection. Cable counts do not approach fill rate limits so it is acceptable to route both copper and backbone fiber optic cabling within the same Wyr-Grid® Channels instead of creating an additional overhead pathway tier. However, the disparate cable bundles are kept separate within the shared pathway by using Panduit® Tak-Ty® Hook & Loop Cable Ties to position the bundles along the pathway edges.

Grounding and power cables must also be managed in an efficient manner in this design. Figure 8 provides a close-up of how the grounding, copper, and fiber optic cabling route via the overhead pathways. Conduit underneath the raised floor routes power whips from rack mounted power outlet units (POUs) to electrical panels and other power distribution units (PDU) and uninterruptible power supplies (UPS) within the building. The figure is followed by the best practices for pathways, summarized in the following table.

Figure 8 - Close up on overhead pathways cabling

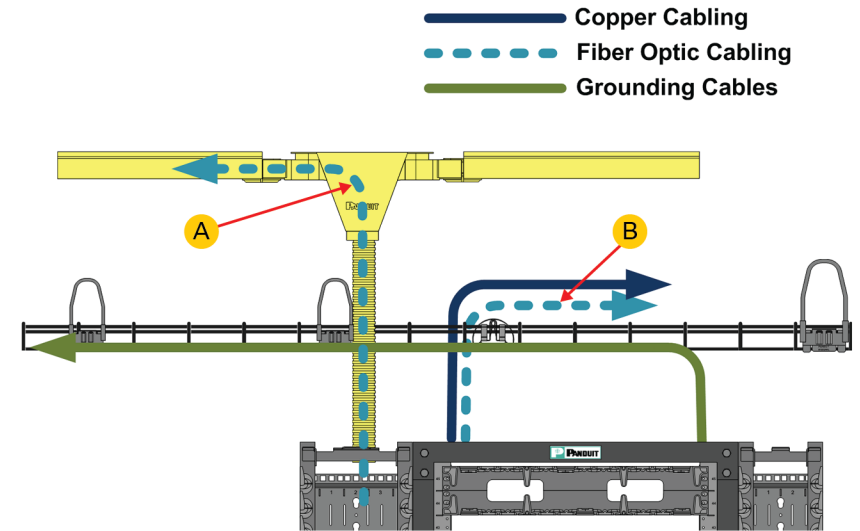

- A** Panduit® Opti-Core® LC-to-LC 10Gig™ OM3 Multimode Duplex Patch Cords in FiberRunner® Routing System
- B** Panduit® Opti-Core® OM3 Riser Distribution Cable routed on Wyr-Grid® Pathway System

Table 2 - Pathways best practices

| Configuration best practices | ✓ Alignment to Cisco SBA Designs |
|---|---|
| Maintain adequate distances between pathways and premise ceiling or slab floor in overhead and underfloor applications, respectively. | <ul style="list-style-type: none"> ✓ Panduit® Wyr-Grid® System mounts a minimum of 4 in. (102 mm) above top of racks, and FiberRunner® System Channels mount 12 in. (305 mm) above the bottom of the Wyr-Grid® System. An 18 in. (457 mm) buffer is kept between the ceiling and top of the FiberRunner® System. ✓ To use GridRunner™ in an office space raised floor installation, the raised floor should be a minimum of 8 in. high (203 mm) for a 4 in. deep (102 mm) pathway and 10 in. high (254 mm) for a 6 in. deep (152 mm) pathway. |
| When mixing copper and fiber optic cabling in a shared pathway, steps must be taken to effectively manage and separate the disparate cable bundles. | ✓ Wyr-Grid® System routes Category 6A copper cabling and OM3 Riser Distribution Fiber Optic Cables in the same shared pathway. Tak-Ty® Hook & Loop Cable Ties are used to keep the disparate cable bundles merged to the opposite edges of the pathway. |
| Use different pathways to keep adequate separation between copper and power cabling. | ✓ GridRunner™ System routes copper cabling under the raised floor. Power cables from rack mounted POUs route through conduit under the raised floor. |
| Pathways made of metallic material must form a proper mechanical bond, ensuring electrical continuity throughout the system. | ✓ Wyr-Grid® System and GridRunner™ System automatically create electrical continuity during installation without the need for jumper wires, saving not only installation cost and time, but also ensuring against accidental discontinuities during both the initial construction and future renovations. |
| Provide adequate room in pathways for future expansion. | ✓ Pathways have been sized to ensure a best practice channel fill rate of less than 50%. |
| Configuration should allow for simple moves, adds, and changes. | ✓ QuikLock™ Assembly features on FiberRunner® Systems and snap-on components in Wyr-Grid® System and GridRunner™ System eliminate or minimize the need for many tools for assembly. Level and directional changes are also easy to accommodate with all pathway systems for working around obstructions. |
| Ensure proper protection for cabling into pathways. | ✓ Bend radius control is maintained with all systems to protect against signal loss due to excessive cable bends. FiberRunner® System and Wyr-Grid® System both provide spill out accessories that ensure bend radius control for entering and exiting the pathways. |

LAN Access Network Cabling

It is appropriate to consider the media (such as copper and fiber cabling) used to transport Ethernet data between LAN access layer switches and end points, for example, desktops and work stations. A significant part of this consideration centers on the development of standards for and deployment of equipment supporting higher data rates. For example, even as adoption of 10-G Base-compliant fiber and copper solutions grows, some user groups, such as video-content providers, financial institutions, and consumer broadband providers, are already demanding data rates higher than 10 Gb/sec.

The typical life of an IT installation can reach 10 to 15 years, and with regular maintenance and upgrades, the facilities, infrastructure and cabling plant are also expected to last as long. Active equipment refreshes commonly occur every three to five years, so cabling systems are expected to support multiple generations of IT equipment. Most IT installations contain a mixture of 1 Gb/s and 10 Gb/s structured cabling systems with 1 Gb/s (transitioning rapidly to 10 Gb/s) being the prevalent data rate for most data link connections and four to eight Gb/s for most storage link connections (through Fiber Channel to and from the storage area network (SAN)). Therefore, it is easy to see why content providers are already considering even higher data rates than 10 Gb/s to be critical in their roadmaps to success. These considerations led to the decision to deploy 10 Gb/s structured cabling throughout the reference design example—from the TRs all the way through to the work areas.

Panduit Fiber Cabling Solutions

Comprehensive Panduit fiber optic cabling systems include a full line of innovative, high performance products such as media, connectors, and pre-terminated components that are designed to meet the demands of today's requirements, and provide the capacity to accommodate tomorrow's applications.

With industry-leading optical performance and signal integrity, Panduit fiber optic systems deliver reliability and scalability to enable enterprise application availability and agility. These systems offer the industry's highest patch-field density and superior cable management to deliver unmatched network design and layout flexibility.

These systems deliver reliable 10 Gb/s Ethernet performance, at a reach of up to 300m with Panduit proprietary OM3 fiber and up to 550m with Panduit proprietary OM4 fiber, with additional headroom above the standard for data integrity and optimum network performance. This performance is summarized in the following table.

Table 3 - OM3 and OM4 performance summary

| Physical Media Dependent (PMD) | OM3 | Panduit OM3 | OM4 | Panduit OM4 |
|--------------------------------|-------------|-------------|-------------------------|-------------------------|
| 10GBASE-SR/SW | 2000 MHz-km | 2300 MHz-km | Not covered in standard | Not covered in standard |
| 40GBASE-SR4 | 2000 MHz-km | 2300 MHz-km | 4700 MHz-km | 5000 MHz-km |
| 100GBASE-SR10 (draft) | 2000 MHz-km | 2300 MHz-km | 4700 MHz-km | 5000 MHz-km |

The use of OM4 fiber also helps you prepare for the almost inevitable deployment of 40 Gb/s links from the data center to the TRs.

OM3 Fiber Optic Media

The Panduit OM3 Fiber Optic System features the highest quality laser optimized OM3 fiber (with a minimum effective modal bandwidth (EMB) of 2300 MHz-km) to support network transmission speeds up to 10 Gb/s, for link lengths up to 300m with an 850nm source per the IEEE 802.3ae 10 GbE standard. Panduit OM3 systems enable additional headroom at 300m, because these cables are manufactured to exceed standards-based minimum EMB requirements by 10%.

OM4 Fiber Optic Media

The Panduit OM4 Fiber Optic System is designed for very high performance applications requiring long reach capability and/or cascaded connectivity (for example, cross-connects) with ample headroom. OM4 systems integrate multi-fiber low-loss MTP and single-fiber connectivity solutions with premium grade high performance laser optimized multimode fiber (with a minimum EMB of 5000 MHz-km) in order to deliver consistent performance and reliability for mission-critical systems.

Specifically, these modular systems include pre-terminated cassettes, interconnect assemblies, equipment cords, and harnesses. Pre-terminated LC cassettes feature high-density MTP connectors and small form factor LC connectivity. Low-loss cassettes interconnect with OM4 multi-fiber MTP terminated ribbon assemblies for scalability and quick cross-connection of long data center segments.

Panduit Copper Cabling Solutions

The copper cabling performance category to be used in the organization should be addressed early in the design process. Generally, the choices that are available range between Category 6 for support of 1-Gigabit data transmission and 10-Gigabit data transmission over restricted distances (with some requirements regarding cable bundles); and Category 6A for full one hundred meter channel transmission of 10-Gigabit data. Panduit also has available a small diameter Category 6A cabling solution that is useful in cases where pathway space is limited or restricted. This small diameter cable solution supports 10 Gb/s data transfer over a 70 meter channel. For reference, this solution will also support 1 Gb/s data over the 70 meter channel. The following table lists some of the key parameters of the three different cable systems, and gives broad guidelines regarding when one cable type may be preferred over other cable types.

Determining the cabling type to be used in the reference building described earlier involved two main factors. The first was the expected length of the installed life of the cabling. The expected installed life is long, therefore factors that need to be considered include several active equipment refresh cycles and that data transmission rates would generally trend to faster. The second consideration was the need to accommodate some runs of greater than 70 meters. As a result, Category 6A cabling capable of being deployed out to channel lengths of 100 meters was chosen, specifically TX6A™ 10Gig™ UTP Copper Cable.

The TX6A™ 10Gig™ UTP Copper Cable with MaTriX Technology is a component of the TX6A™ 10Gig™ Copper Cabling System. Interoperable and backward compatible, this end-to-end system provides design flexibility

to protect network investments well into the future. The TX6A™ 10Gig™ Copper Cabling System comprises an optimized set of components including copper cable, jacks, patch cords, and patch panels.

The Copper Cabling System exceeds certified channel performance in a four-connector configuration up to 100 meters. It also exceeds the requirements of ANSI/TIA-568-C.2 Category 6A and ISO 11801 Class EA standards for supporting 10GBASE-T transmission over twisted-pair cabling systems as part of the Panduit® TX6A™ 10Gig™ UTP Copper Cabling System certified component performance up to 100 meters. It exceeds the ANSI/TIA-568-C.2 Category 6A and IEC 61156-5 Category 6A standards for supporting 10GBASE-T transmission over twisted-pair cabling systems.

MaTriX Technology in the cable, combined with the split foil MaTriX Technology and advanced connector compensation techniques in the TX6A™ 10Gig™ UTP jack modules, result in a guaranteed headroom margin well above industry standard requirements. The resulting channel performance eliminates the time and cost associated with cumbersome alien crosstalk field testing.

The enterprise example used as the basis for this reference architecture is a green field site, where the cabling system deployed supports and exceeds the requirements for the full 100 meter channel, in order to accommodate the longest cable lengths in this case. The Panduit TX6A-SD™ 10Gig™ UTP Copper Cabling System with MaTriX Technology is a cost effective, small diameter Category 6A UTP cabling system that is fully compliant up to 70 meters (230 feet). This high performance cabling system is comprised of unshielded twisted pair horizontal cabling and patch cords that utilize 26 American Wire Gauge (AWG) copper conductors and patent pending MaTriX Technology to suppress alien crosstalk. Most Category 6A cabling utilizes 23 AWG copper conductors, with the industry standard ANSI/TIA-568-C.2 generically specifying 22 to 24 AWG horizontal cable with 26 AWG patch cable.

The primary difference between smaller and larger wire gauges is signal attenuation: the attenuation of a 26 AWG cable at 70 meters is similar to that of 23 AWG cable at 100 meters, with all other electrical parameters of a Category 6A component and channel requirements being met. A 26 AWG system significantly reduces the diameter of the cable and results in a cabling system that is easier to install and is an especially attractive option for use in existing sites, for example, brown field, where existing and possibly size restricted pathways may be serious limiting factors when considering a deployment upgrade to a 10-Gigabit system.

Table 4 - Copper cabling type comparison

| Attribute | Category 6 | Category 6A | Category 6A SD |
|---|--|---|---|
| Cable type | TX6000™ High Performance Cat 6 UTP Copper Cable | TX6A™ 10Gig™ UTP Copper Cable | TX6A-SD™ 10Gig™ UTP Copper Cable |
| Part number plenum / riser, color - Blue (BU) | PUP6004BU-UY / PUR6004BU-UY | PUP6A04BU-UG / PUR6A04BU-UG | PUP6ASD04BU-CG / PUR6ASD04BU-UG |
| Diameter, inches (mm) | 0.240 (6.1) | 0.300 (7.6) | 0.240 (6.1) |
| Channel length maximum, meters | 100 m | 100 m | 70 m |
| Data rate | 1 Gb/s, 10 Gb/s to channel length of 55 meters if lightly loaded pathway; 37 meters if many cables are bundled together | 10 Gb/s over maximum channel length | 10 Gb/s over maximum channel length |
| Conductor gauge | 23 AWG | 23 AWG | 26 AWG |
| Wire Fill for Wyr-Grid® Overhead Cable Tray Routing System, 50% allowable fill, 12-inch wide, 4-inch high | 538 | 344 | 538 |
| Deployment Examples | Individual cables from zone enclosure to the work area for applications not requiring 10 Gb/s, e.g. office desktop type applications | Main trunk runs from TR to zone enclosure in green field deployments or where cabling density is not an issue in brown field deployment | Main trunk runs from the TR to zone enclosure where cable density is a concern |
| | — | Larger enterprises where channels may include runs up to 100 meters | Smaller enterprises where channels will only include runs up to 70 meters |
| | — | Cabling to the work area where high data rates are required | Cabling to the work area where high data rates are required |
| | — | Installation where cabling is expected to have a long life, for example, 10 to 20 years | Installation where cabling is expected to have a long life, for example, 10 to 20 years |

Telecommunications Room Deployment

The following figure presents a front elevation of the TR racks with the physical infrastructure components labeled. The racks involved in this design all have the same standardized elements recommended in the *Cisco SBA—Borderless Networks LAN Deployment Guide*. In addition to the Cisco Catalyst 4507 R+E switches used for access layer switching, physical infrastructure components such as horizontal cable managers, vertical cable managers, angled patch panels, and pre-terminated cabling provide the modularity needed for the solution.

- A** FiberRunner® Pathway System - 2 in. × 2 in. (50.8 mm × 50.8 mm)
- B** Wyr-Grid® Pathway System - 12 in. (305 mm) width, utilizing optional 4 in. (102 mm) sidewalls
- C** 4 Post Rack System (45 RU) – 84 in. H × 23.3 in. W × 36.2 in. D (2133.6 mm × 591.82 mm × 919.48 mm)
- D** PatchRunner™ Vertical Cable Management System - 8 in. (203.2 mm)
- E** GridRunner™ System - 12 in. × 4 in. × 48 in. (305 mm × 100 mm × 1219 mm)
- F** Flexible conduit for power cabling

Figure 9 - Rack elevations of the TR closet

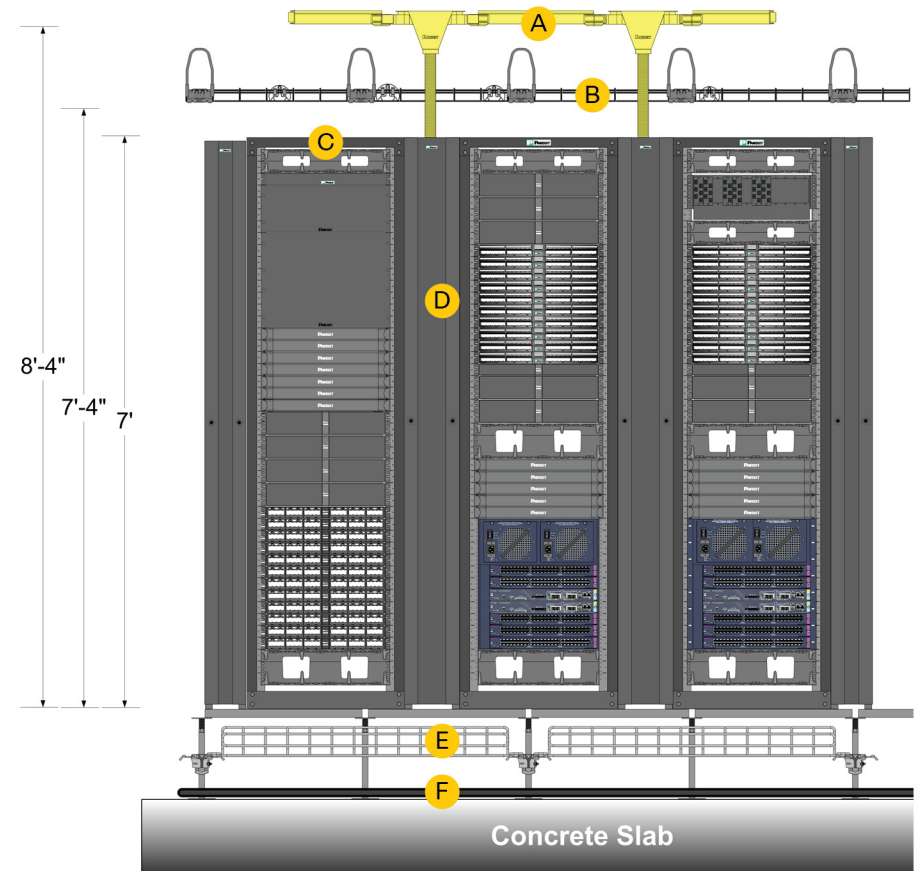

Special attention must be given to both logical and physical security in these TR deployments. As mentioned in the logical architecture sections, VLANs can be configured with the appropriate access control lists (ACLs) and/or firewalls that restrict access to those VLANs. For physical security, Cisco IP Video Surveillance Cameras mounted in the TRs record video to DVR servers in the data center. Entry to the TRs is effectively managed by deploying door access control using the Cisco Physical Access Gateway in conjunction with the Cisco Physical Access Manager. Within the TR, Panduit's PanView iQ™ (PViQ™) System Hardware combines industry-leading innovation of intelligent cabinet devices with complete system management through Panduit's Physical Infrastructure Manager™ (PIM™) Software Platform. This combination of active patch panels, cabling, power outlet units, and environmental sensors provides a complete solution. Information about these devices can be accessed on site or remotely through a web-based interface in order to troubleshoot and execute on physical infrastructure changes for greater efficiency and cost savings.

Panduit PViQ™ Patch Panels, Intelligence Modules, and PViQ™ Copper Interconnect Patch Cords are used to detect any unauthorized patch field modifications in the networking racks. In addition, Panduit® RJ45 Jack Blockout devices are used to seal any unused switch ports or patch panel ports, as well as patch cord plug lock-in devices being used to prevent unauthorized patch cord removal. With these security mechanisms in place, management can be confident that all access to critical business equipment is authorized and traceable.

By employing cable routing and management best practices indicated in the following table, the racks provide easy access to device components during maintenance windows and ensure proper cooling efficiency. It is imperative that cabling does not block easy insertion and removal of Field Replaceable Units (FRU) on any equipment or block hot air exhaust outlets. The patch cords themselves should also be easy to trace in troubleshooting scenarios and easy to move, add, or change during proactive maintenance routines. In addition to the best practices for cable routing and management described in the table, cabling traceability is made much more straightforward by the use of an industry standards based, TIA-606-A, labeling scheme. This is described later in this reference architecture in the "Identification" section of the Additional Physical Infrastructure Elements.

Notes

Table 5 - Racks and cable management best practices

| Configuration best practices | ✓ Alignment to Cisco SBA Designs |
|--|---|
| TR racks | |
| Select racks with attachable vertical pathways to provide optimal cable routing. | ✓ 6 in. (152 mm) and 8 in. (203 mm) wide PatchRunner™ Vertical Cable Management System provides this functionality for the four-post racks. |
| Vertical cable managers must include appropriate accessories to ensure proper bend radius control and cable routing flexibility. | ✓ PatchRunner™ System includes vertical cable management fingers and slack management spools. |
| Vertical footprint of racks must be sufficient to accommodate all equipment and future needs. | ✓ 45 RU racks provide a significant amount of vertical space for current and future needs. |
| Use blanking panels in racks and cabinets to direct airflow and reserve rack space for future use. | ✓ 1 RU and 2 RU Panduit tool-less blanking panels and rack filler panels are leveraged throughout the design to achieve this design goal. |
| TR patch field management | |
| Select patch panels with necessary intelligence to detect physical layer connectivity issues. | ✓ PViQ™ Patch Panels, Intelligence Modules, and PViQ™ Patch Cords in conjunction with Panduit Physical Infrastructure Manager™ (PIM™) software provides real-time monitoring and management of all patch field connectivity to capture planned and unplanned changes. Guided MACs, as well as guided patch cord tracing is possible with this technology. |
| Select patch panels that provide proper bend radius control and cable routing flexibility. | ✓ PViQ™ Angled Patch Panels facilitate proper bend radius control and minimize the need for horizontal cable managers, which saves additional rack units. |
| Patch panels should be simple to work with allowing for faster moves, adds, and changes. | ✓ PViQ™ Patch Panels, Intelligence Modules, and PViQ™ Patch Cords in conjunction with Panduit Physical Infrastructure Manager™ (PIM™) software allow for visually guided MACs and provide instant notification of incorrectly completed tasks. |
| TR horizontal cable management | |
| Horizontal pathways should exist in racks to efficiently route cabling while maintaining proper bend radius control. | ✓ Panduit® NetManager™ High Capacity Horizontal Cable Managers provide large front finger openings for high density and curved surfaces for bend radius control. |
| Cable managers must accommodate future growth. | ✓ The appropriately sized NetManager™ Cable Managers are selected in this design to achieve a fill rate of less than 40% to ensure space for future growth. |
| Prefer 1 RU and 2 RU cable managers to encourage re-use. | ✓ 1 RU and 2 RU Horizontal Cable Managers are primarily used in this design so they can be repositioned after device upgrades or other MACs. |
| Pass-through holes must exist to allow front to rear cabling. | ✓ Both the horizontal and vertical cable managers recommended in this design have pass-through holes. |

The following figure illustrates the cabling strategy used in rack F4 in the TR. In this reference design, the Cisco Catalyst 4507 R+E switch is chosen for access layer functionality as described in the *LAN Deployment Guide*. Each TR in the building contains two of these switches, each of which are configured to provide 240, 1000Base-T Ethernet ports for computer terminals, IP phones, Cisco IP surveillance cameras, Cisco physical access gateways, printers, and other end-user devices spread throughout the office.

Figure 10 - Cable routing inside rack F4

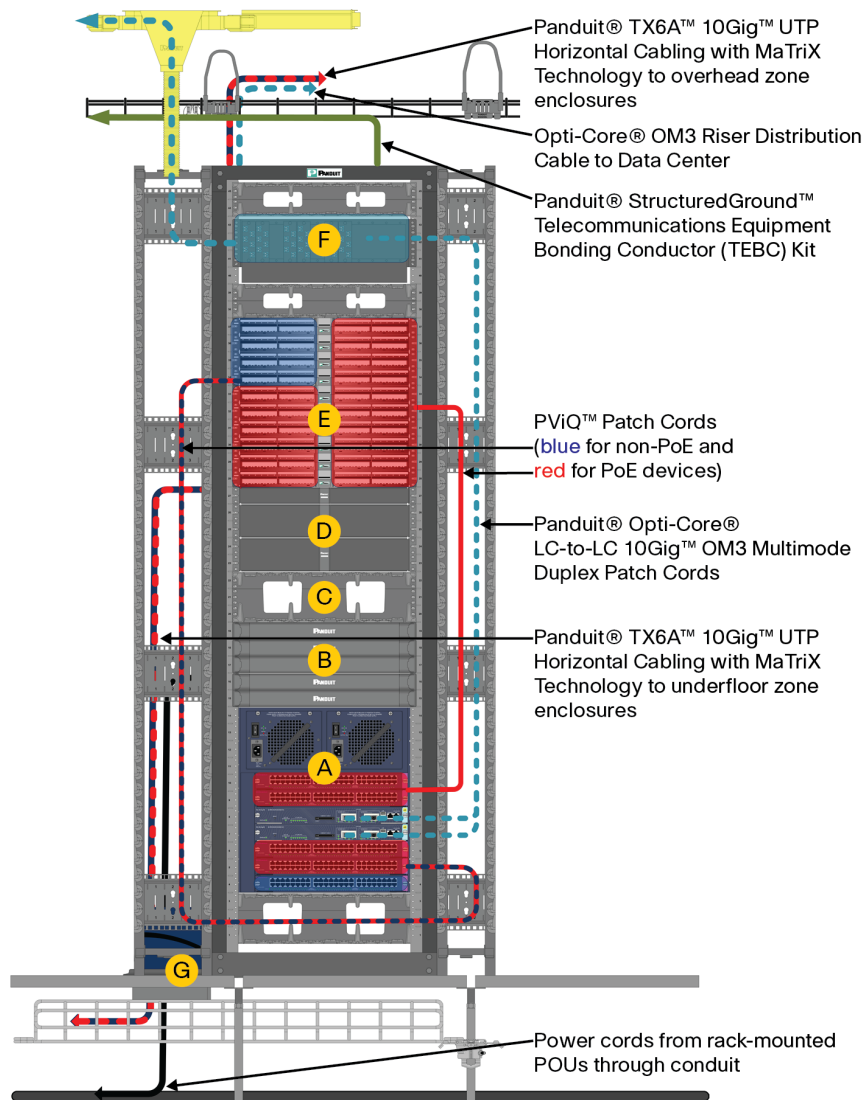

- A Cisco Catalyst 4507 R-E Switch (Access Layer Switching)
- B Panduit® Tool-less Blanking Panels
- C NetManager™ High Capacity Horizontal Cable Managers
- D Panduit® Angled Filler Panels
- E Panduit PVIQ™ 24 Port Angled UTP Modular Intelligent Patch Panels
- F Opticom® Rack Mount Fiber Enclosure with LC Fiber Adapter Panels (OM3)
- G Cool Boot® Raised Floor Air Sealing Grommet

The four Catalyst 4507 R+E access switches per floor (two per TR) have an adequate amount of connectivity to fulfill the requirements of the example use case in this reference design. Each TR needs to supply copper connectivity to approximately 400 devices (IP phones/PCs, printers, other IP capable devices, etc.) on their half of the floor. In total, the four Catalyst 4507 R+E switches on each floor can accommodate approximately 960 endpoint devices. PoE line cards are used to provide PoE capabilities required by the IP phones and other devices. The switches are also populated with redundant supervisor modules and power supplies for maximum resiliency.

PVIQ™ Copper Interconnect Patch Cords are routed from the Catalyst 4507 R+E switches to PVIQ™ Patch Panels, which provide connectivity monitoring for the switch ports. Intelligent patch panels guide moves, additions, and changes and alert administrators to incorrect patching operations. Panduit® TX6A™ 10Gig™ UTP Horizontal Cabling with MaTriX Technology route from the rear of these patch panels to zone consolidation enclosures on the office floors. Each of the zone enclosures is populated with QuickNet™ Patch Panels populated with QuickNet™ Pre-Terminated Cable Assemblies. TX6A™ 10Gig™ UTP Patch Cords with MaTriX Technology then connect from the zone enclosures to endpoint devices.

As explained earlier, the bundles of copper cabling route from the TRs both under the raised floor and overhead via GridRunner™ Systems and Wyr-Grid® Systems, respectively. The J-Pro™ Cable Support System can also be used for pathways exclusively or in combination with the GridRunner™ Systems and Wyr-Grid® Systems. Opti-Core® Riser Distribution Cable (OM3) acts as backbone cabling that runs behind these enclosures to the data center. Then, Opti-Core® LC to LC 10Gig™ OM3 Multimode Duplex Patch Cords run from the front of the fiber enclosure to the 10 Gb uplinks in the Catalyst 4507 R+E switches.

Figure 11 - Copper and fiber jack block-out devices and tools

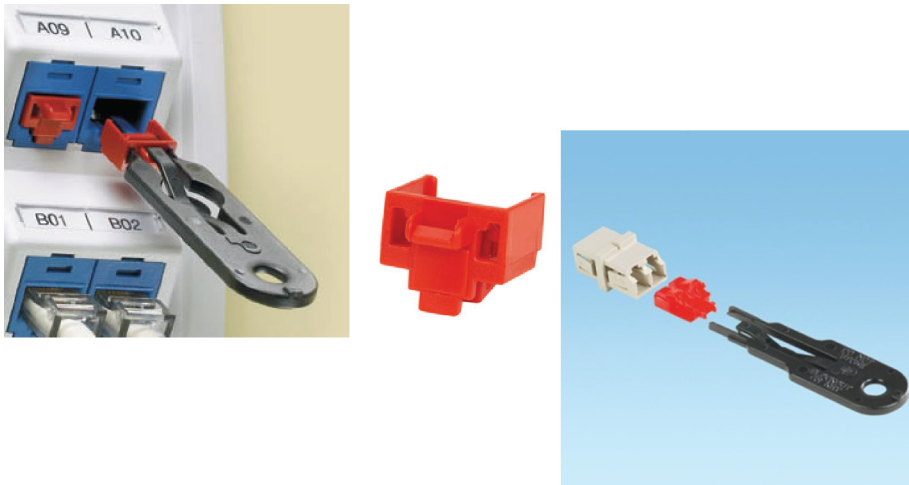

Unused fiber or copper ports in the patching field can be fitted with RJ45 or fiber jack block-out devices. The devices are easily fitted into an open jack, but a tool is required to remove them. The devices block unauthorized access to jacks and potentially harmful foreign objects, saving time and money associated with data security breaches, network downtime, repair, and hardware maintenance. Figure 11 shows an image of the copper and fiber jack block-out devices and tools.

Conversely, fiber and copper ports that are in use, and appropriate patch cords installed can utilize the plug lock-in device that secures the plug into the jack so that it cannot be removed without a tool. The tool is also needed to install the device. The tamper-resistant design blocks the unauthorized removal of cable, VoIP phone, other networking equipment, or critical connections. Figure 12 shows an image of the copper and fiber plug lock-in devices and tools.

Figure 12 - Copper and fiber plug lock-in devices and tools



The QuickNet™ Plug Pack Housing is a recommended item for use with large numbers of patch cords typically encountered in the vicinity of and connected to high density (48 x RJ45 ports in a 1 RU space). The QuickNet™ Plug Pack is an assembly that holds groups of patch cord plugs in a defined geometric arrangement to facilitate groups of patch cord plugs being easily engaged into or disengaged from switches. Facilitating quick and easy connection and removal of patch cords from a variety of Cisco Catalyst switches results in a reduction in the time and cost associated with installing and maintaining structured cabling links. In addition, there is an improvement in the accuracy of the connections because the Plug Pack retains the patch cords in their designated configuration if a switch card is removed and replaced.

The QuickNet™ Plug Pack Housing is available in 6, 8 and 12 position designs for different switch port layouts. An optional lock-in device is available to prevent accidental or unauthorized removal of the housing from the switch. In addition, an optional tool is available that allows a single patch cord to be disconnected from the switch. This feature is useful if a single patch cord is damaged and requires replacement without all the patch cords in the housing being removed if the housing was disengaged from the switch.

Figure 13 - QuickNet™ Plug Pack housings—from l to r: 6-, 8-, and 12-position



Figure 13 shows the QuickNet™ Plug Pack housings for 6-, 8-, and 12-position designs. The 6- and 12-position designs are used with switch cards that have 48 ports made up of 4 x 12 port jack modules; the 8-position design is used with switch cards that have 48 ports made up of 3 x 16 port jack modules. The following table shows the QuickNet™ Plug Pack base part numbers that can be used with a variety of Cisco Catalyst switches.

Table 6 - QuickNet™ Plug Pack to be used with Cisco catalyst switches

| Cisco Switch Series | Type | Base Part Number |
|------------------------------|---------------------------------------|--|
| Catalyst 6000 | 6 position 12 position | QPPN6 ¹ QPPN12 ¹ |
| Catalyst 4000 | 8 position | QPPN8 ¹ |
| Catalyst 3750, 3560, 2960 | 6 position or 8 position ² | QPPN6 ¹ or QPPN8 ^{1 2} |

¹ Release level color (BL, BU, RD, WH)

² Defined by port layout of specific switch

Figure 14 more closely examines rack D4 in the TR. In the example enterprise, this rack hosts the non-IP enabled BAS devices and the fieldbus patch field. Components labeled in Figure 14 are not re-examined here. Cable routing in this rack involves only RS-422 and RS-485 fieldbus cables and power cords. No fiber optic cabling is necessary in D4 at this time, but the FiberRunner® System is positioned above this rack in case fiber cable installations are necessary in the future.

The fieldbus cables run either overhead in Wyr-Grid® Systems or under the raised floor in GridRunner® Systems depending on where zone consolidation enclosures are physically located out on the office floors. Configuring the Mini-Com® Angled Modular Patch Panels as depicted in Figure 14 provides connectivity for up to 96 BAS controllers and endpoints that are hosted out of each TR. Since there are two TRs on each floor, a potential total of 192 BAS entities could be connected per floor. Currently, there are only about 100 BAS endpoints on each floor, therefore provision is made for future expansion, if required.

Figure 14 - Cable routing inside rack D4

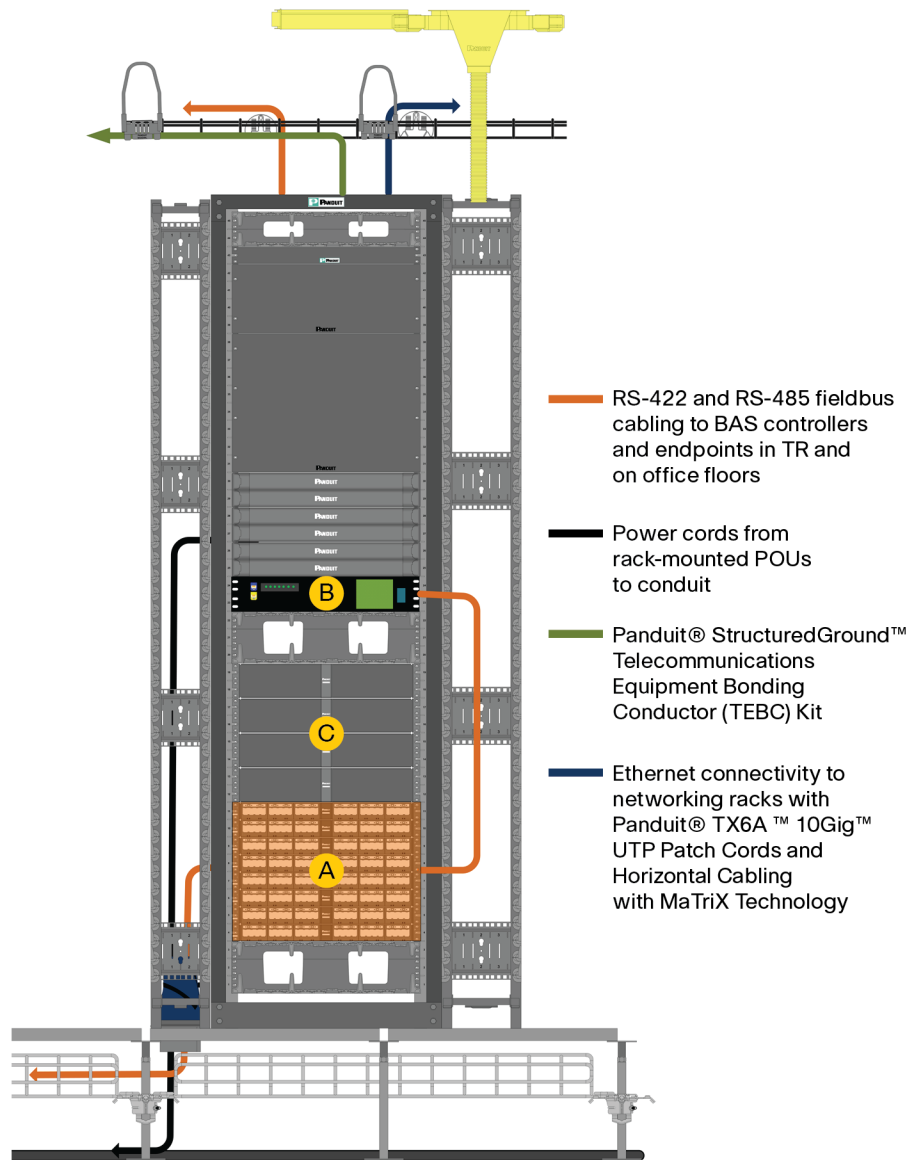

- A** Mini-COM® Ultimate ID® Angled Modular Patch Panels populated with Mini-COM® BAS Connector Modules
- B** Rack-mounted BAS Controller
- C** Angled rack filler panels

Environmental Design

In order to achieve maximum efficiency and optimization in this design, the appropriate cooling design and power distribution configurations must be employed. Best practices followed in larger data center implementations are equally applicable in the TR. In the cooling system, the objective is to provide an adequate cold air supply to the IT equipment and properly remove hot exhaust air. With a properly implemented power distribution system, IT equipment remains available even during power outages or service disruptions.

Cooling System

Since the TRs in the reference building are sited on each floor of a multi-level building, and are also located towards the center of the building, direct access to outside air for potential use as an economizing measure is not readily available. In this case, the TR cooling is accomplished by recirculation of air through a cooling coil in the telecom space. The reference building design incorporates computer room air handling (CRAH) units mounted on the ceiling and fed by recirculating chilled water.

The location of active equipment such as the switches is very important for the cooling system. Typically these would be placed towards the bottom of the four-post rack in order to improve the stability of the rack, but concerns have to be addressed if this is the preferred equipment location. If the two Catalyst 4507 switches are mounted in adjacent racks, one switch will pre-heat the inlet air for the second switch (Figure 15).

In this figure, the 4507 switches are mounted in adjacent racks in RU 4. This arrangement is acceptable as long as the exhaust air temperature from the first switch is less than the recommended ASHRAE inlet temperature value (80.6 °F). However, with a typical device utilization of 50% of nameplate power, the exhaust temperature from the first switch is well over the ASHRAE limit. Per the Computational Fluid Dynamics (CFD) analysis, the average inlet temperature for the second switch is 101 °F. In order to meet the desired inlet temperature, the room cooling supply temperature would need to be reduced by over 20 °F, resulting in an increase in cooling costs, or some other means to reduce the inlet temperature, for example, by using ducting to divert the first switch exhaust.

Figure 15 - Cross-sectional view of the temperature distribution

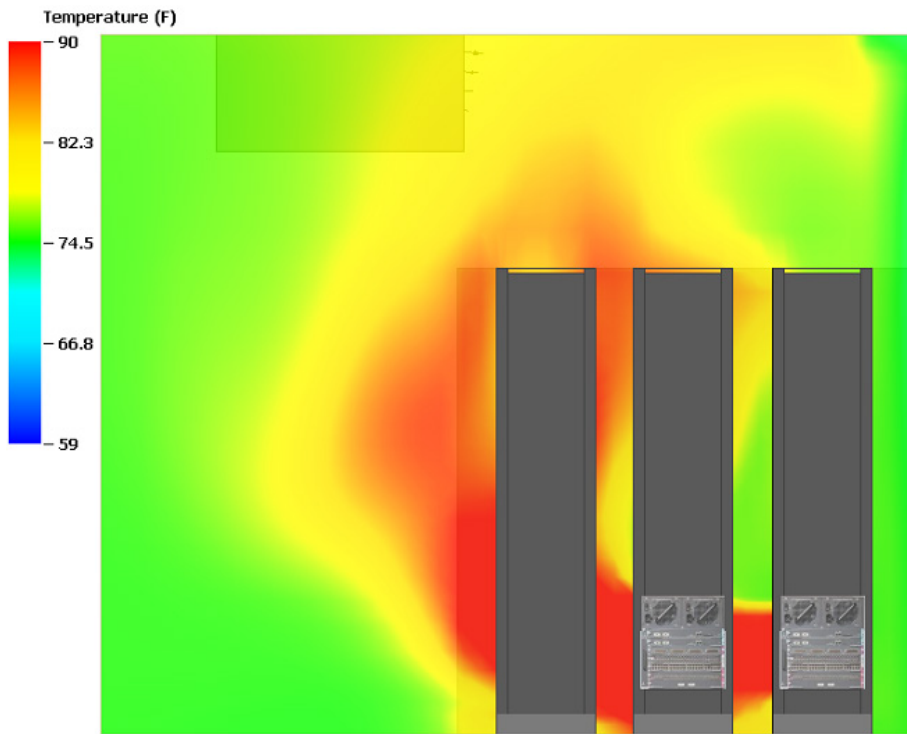

The CFD analysis reveals the following pertinent details:

- The maximum inlet temperature for the datacom equipment is 101 °F. The supply air temperature is 68 °F and an airflow rate of 2500 cfm.
- The Catalyst 4507 switches are mounted in adjacent racks, which results in the prevention of the exhaust of one switch from entering the inlet of the second switch.
- To achieve the ASHRAE recommended inlet temperature, the room supply temperature needs to be 47 °F.

In order to avoid this severe reduction in the room temperature set point, an exhaust duct can be attached to the first switch. Equipping the switch in the right-most rack (Figures 16 and 17) with an exhaust duct effectively prevents the exhaust air of that switch from entering the inlet of the adjacent switch.

Figure 16 - Cross-sectional view of the temperature distribution—exhaust duct

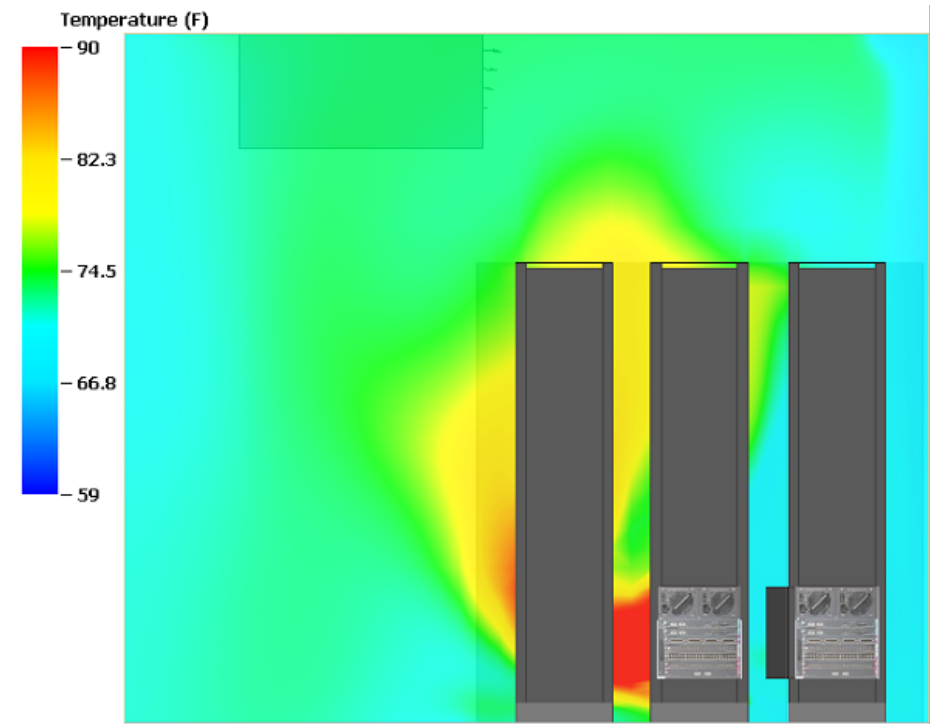
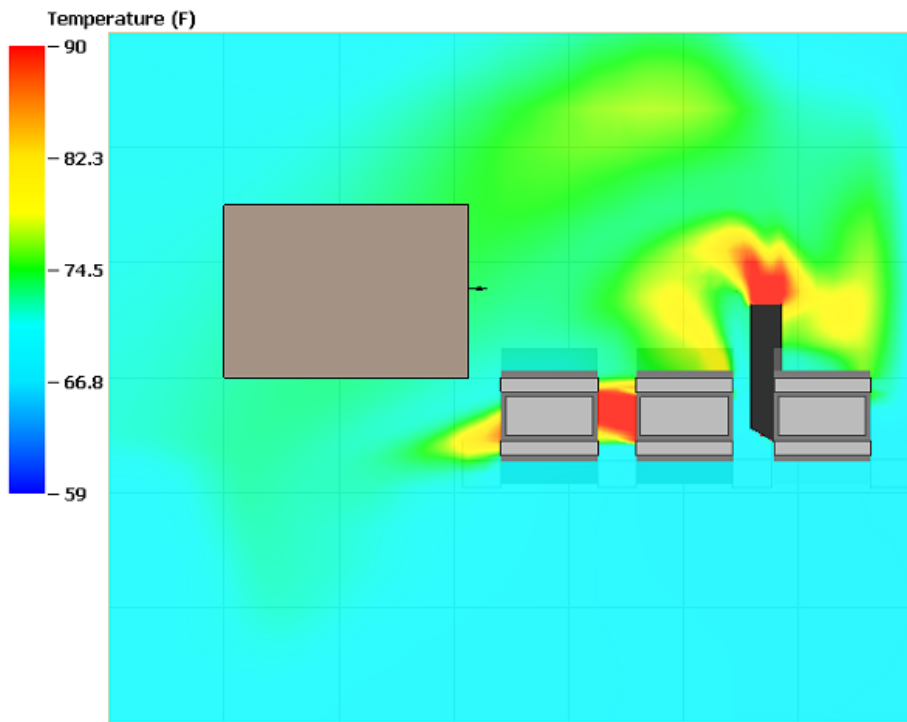

Figure 17 - Plan view of TR temperature distribution on a plane



The CFD analysis reveals the following pertinent details:

- The exhaust duct effectively diverts the exhaust air from switch 1 away from the inlet of switch 2.
- The maximum inlet temperature for the datacom equipment is 80°F. This is accomplished with a supply air temperature of 63°F and an airflow rate of 2500 cfm.

Power System

In the past few years, the importance of the TR, and consequently its design considerations, has grown significantly. A small closet housing a passive punchdown cross-connect field for analog phones in the office has evolved to a room providing power for access switches to deliver data connections to desktops in the work area. As the evolution process continues, the TR requires more power to support Power over Ethernet (PoE) power supplies for voice over IP (VoIP) phones frequently deployed in the office environment. Consequently, cooling becomes an important consideration.

The evolution of the TR continues as building automation services (for example, lighting, HVAC, etc.) converge onto the IT network. When you consider this evolution process, you can appreciate that the importance of the network associated with the TR is approaching that of the data center.

The significance of the TR in the converged network is underscored by the need to maintain the availability of conditioned power in the event of failure or interruption of the utility power feed. One option considered was to deploy rack mounted uninterruptible power supplies (UPS) in each TR and use the utility feed. Concerns over the single point failure potential for such an arrangement led to the reference building used in this architecture utilizing a separate high availability power supply to feed critical elements within the building. The high availability power supply features incorporation of redundant feeds, and redundant uninterruptible power supplies providing conditioned power to the data center and TRs. The availability of the supply is assured by maintaining battery back-up which could supply power in excess of 30 minutes, if required, and a transfer arrangement to external generators that could supply critical requirements for extended unavailability of the utility feed.

The power requirements of the TR are sized to provide 208-volt three phase at 100 amps. Rack mounted POUs fed by the three phase supply are used to provide X, Y, and Z single phase power, 208 volt power feeds to active equipment mounted in the racks.

Zone Cabling Architectures

One of the key enabling technologies of converged physical infrastructures within the enterprise is the use of a zone cabling architecture. Under this approach, all system networks (copper, optical fiber, coaxial, and fieldbus cabling) are converged within common pathways from the TRs to consolidation points. The final termination is within zone enclosures distributed throughout the building, allowing all cables to be managed and patched in a single enclosure. This architecture differs from dedicated cabling runs typically used for enterprise and building systems as depicted in Figure 18. Dedicated runs, also termed home runs, often lead to multiple lengthy and redundant cabling routes along disparate pathways. This leads to inefficiencies in specification, installation, and maintenance.

Figure 18 - Typical cabling infrastructure using long home runs

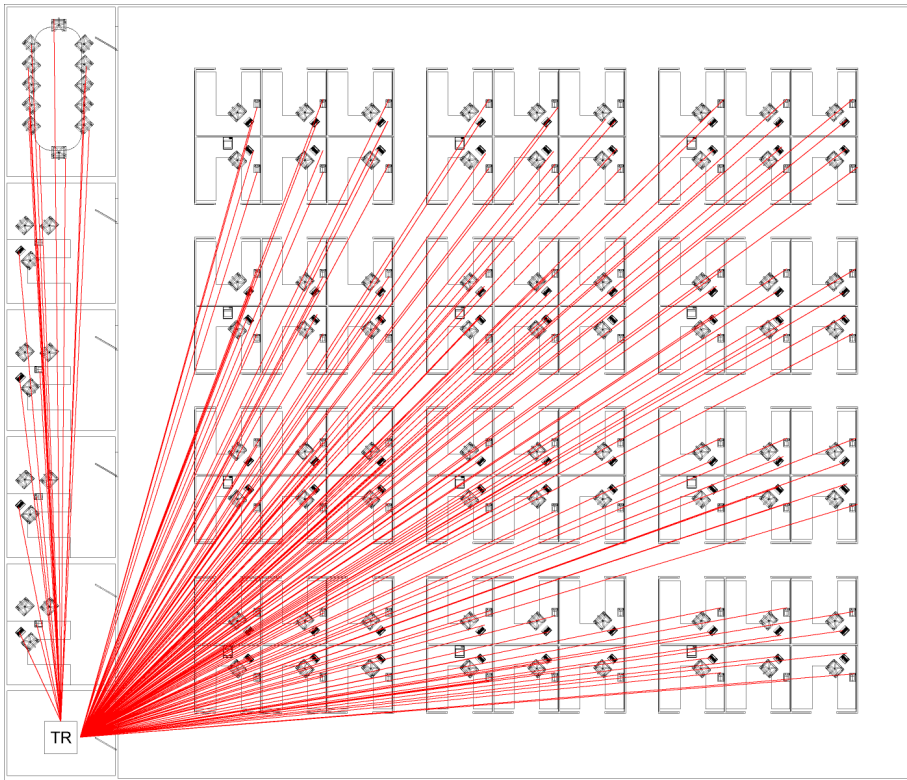

Consolidation Points

Under a zone architecture like the one depicted in the following figure, network cabling becomes easier to locate, manage, and maintain, because each additional building and enterprise system is routed within the same pathways and enclosures. Managed cabling also helps eliminate abandoned cable in ceilings and under raised floors, making the workplace run more efficiently and safely. Zone architecture enables upfront cost savings by virtue of its physical design requiring a “single pull” at installation. Future operational cost savings are realized by reducing the time and effort required for moves, adds, and changes. This localizes changes at the zone enclosure and at user and device endpoints, eliminating the more time-consuming changes (such as at the TR) that a conventional infrastructure requires.

Figure 19 - Summary of zone cabling architecture

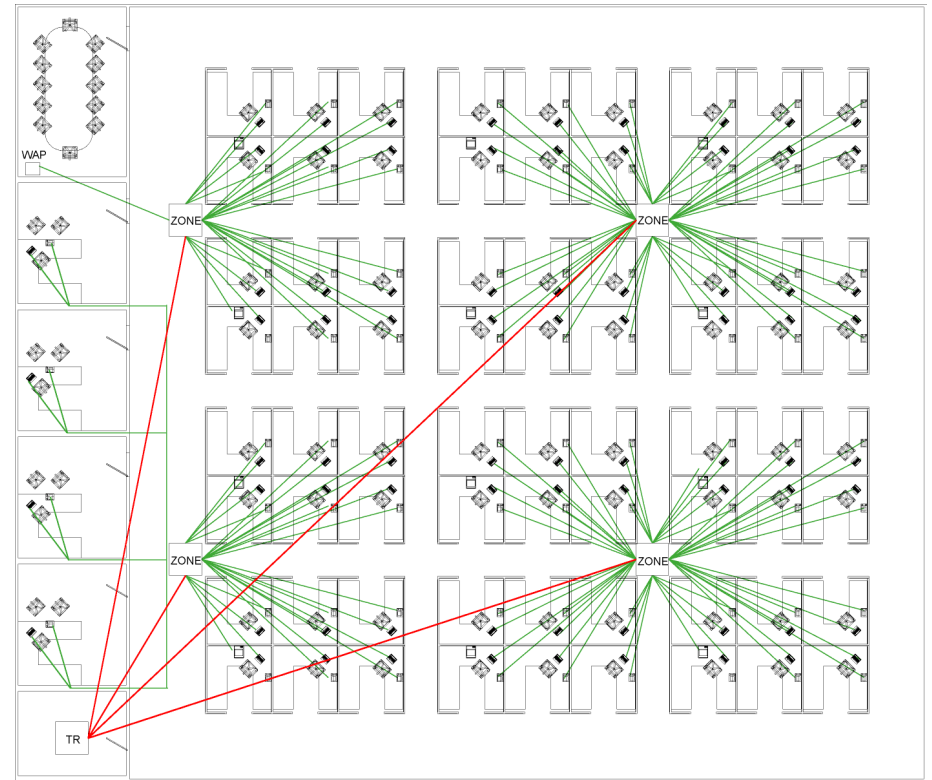

In order to achieve the physical and logical convergence of BAS and enterprise devices, the components within the zone consolidation points must be very modular. As depicted in the previous illustrations, BAS and enterprise systems are networked using a variety of Ethernet and often proprietary RS485 or RS422 communications media. For multimedia applications like digital signage, native RGB composite video and audio can be terminated in zone enclosures close to the screens. Therefore, zone enclosures must be capable of accommodating a wide array of physical connectivity and be located near the devices they support. These enclosures can be located both in the raised floor and drop ceiling.

Figures 20 and 21 illustrate the logical and physical layout of passive zone consolidation enclosures mounted in the building's raised floor and in the drop ceiling, respectively. The organization of patch panels and selected connectivity is very similar. The only essential difference is the type and number of patch panels and Panduit Mini-Com® Modules that would be used to support different IT equipment and BAS communication trunks.

The majority of connectivity on the office floors in this reference design is serviced from underfloor zone enclosures. Therefore, very few overhead enclosures are necessary. Some PanZone® In-Ceiling Enclosures can accept up to 8 RU of standard 19" patch panels; however, only two of them are necessary to accommodate the approximately 100 BAS devices located in close proximity to the drop ceiling on each floor. PanZone® Enterprise In-Floor Enclosures accept Mini-Com® Modules exclusively and contain 24 Category 6A, RJ-45 modules for connecting IT and BAS devices. This reference guide identifies approximately 600 access layer network connections that require underfloor connectivity on each floor. Therefore, administrators would need 25 PanZone® Enclosures distributed throughout the raised floor.

The adoption of a zone cabling scheme also leads to installation advantages, which are very apparent for green field sites. Instead of cables being installed in unique routes from the TR to an end point, multiple cables from the TR to the PanZone® Enclosure are routed and managed together in the GridRunner™ Underfloor Cable Routing System. This means that instead of each cable being pulled, terminated, and tested individually, it is beneficial in terms of installation time to pull groups or bundles of cables along the same pathway. At this point, in traditional installations, each cable could be routed to an end point, terminated and tested as before. However, benefits in terms of installation time and reliability can be achieved by using pre-terminated cable assemblies where the cable has already been cut to length, terminated with connectivity, and pre-tested to assure performance. Further benefits still can be obtained if the pre-terminated assemblies are bundled together in groups of multiple cable assemblies.

The reference building deployed structured cabling using the zone architecture described above, and in particular QuickNet™ Category 6A copper cabling from the TR to the PanZone® enclosures. As part of the complete QuickNet™ Solution, the Panduit™ QuickNet™ Copper Cabling System is a custom pre-terminated cabling solution consisting of a loom of six cable assemblies, designed to meet unique structured cabling requirements. Fast and simple to install, this high density solution provides consistent network reliability and reduces initial onsite re-work. This leading edge system delivers ensured performance for the lowest total cost of ownership. A pre-terminated cabling system simplifies the delivery of these network services

by providing reliable infrastructure components assembled and tested in a factory-controlled environment. An end-to-end pre-terminated cabling system is an ideal solution for the enterprise when time for traditional cable installation, termination and testing is limited. Pre-terminated cable assemblies offer a simple plug and go solution for links between the TR and zone enclosure that can be implemented in either new (green field) or existing (brown field) installations.

Deployment of the zone architecture in conjunction with the QuickNet™ pre-terminated cabling solution gives a very flexible means of providing Ethernet connectivity to work stations and other end points. The work area is often the area that is subject to the most change. When using a secure consolidation point in the form of the PanZone® enclosure work area, changes in the work area layout involve cabling only from the enclosure to the work area rather than making cabling changes all the way back to the TR.

Other benefits of deploying QuickNet™ pre-terminated cable assemblies include the following:

- **Improved site security**—reduced risk arising from reduced installation time, fewer installers, and less time spent on site
- **A unique serial number**—provided for each assembly for easy asset tracking
- **Quick deployment**—up to 75% faster than conventional structured cabling installation
- **Unified copper and fiber solution**—copper and fiber in the same patch panel
- **Green solution**—80% less packaging waste
- **High performance cabling systems**—Category 6A and Category 6 unshielded and shielded copper cabling

Figure 20 - PanZone® enterprise in-floor enclosure

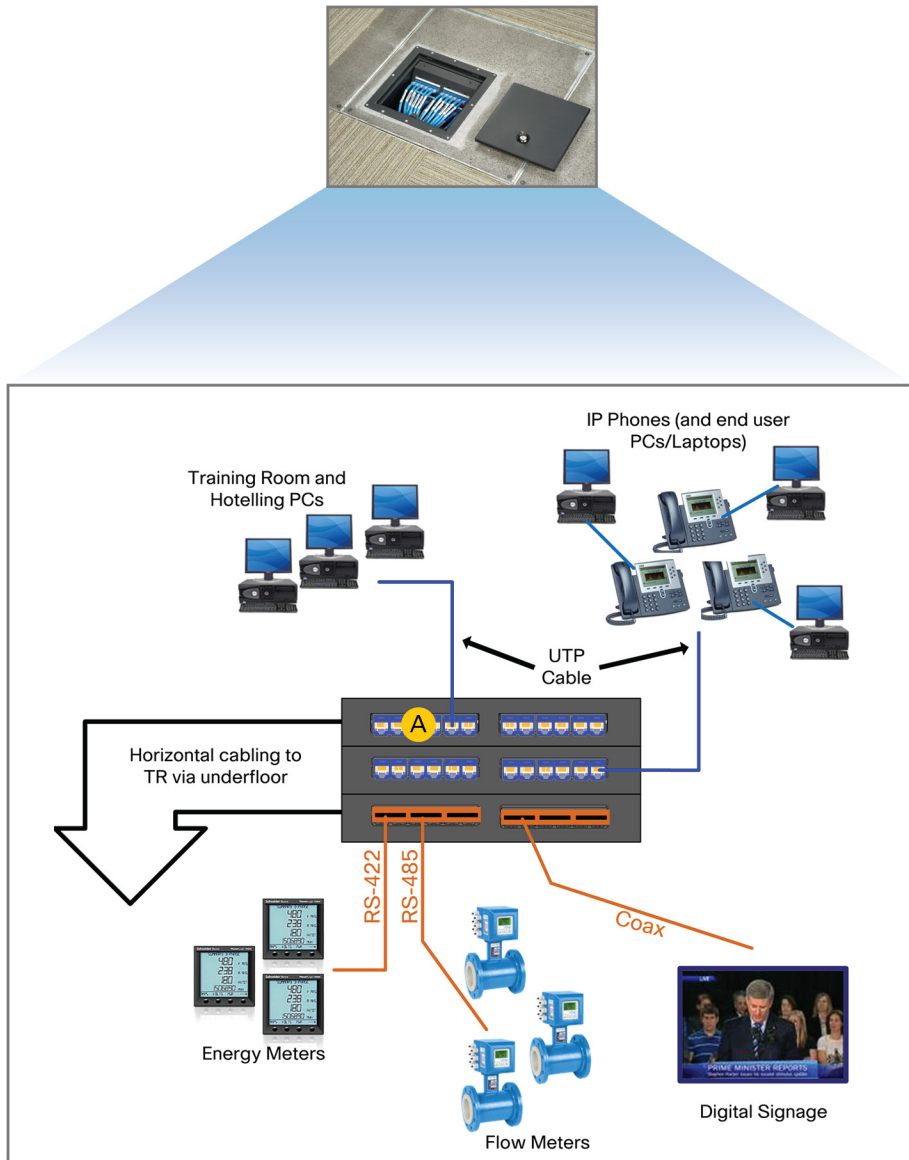

A Mini-Com® Modules inside PanZone® Enterprise In-Floor Enclosure

Figure 21 - PanZone® passive in-ceiling enclosure

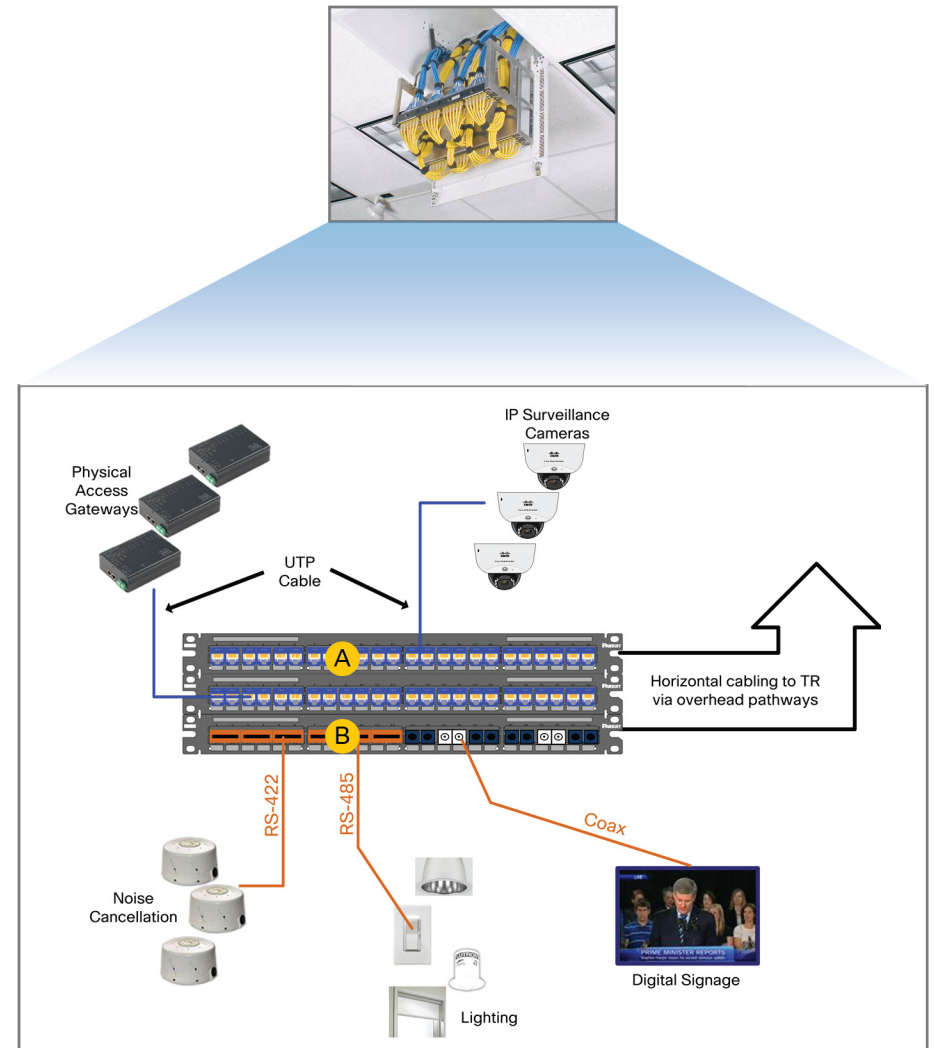

- A** QuickNet™ Patch Panels populated with QuickNet™ Pre-Terminated Cable Assemblies
- B** QuickNet™ Patch Panels populated with Mini-Com® BAS and audio/video Connector Modules

Though not implemented in this reference design building, zone consolidation points can also host active components such as network switches. An active solution can enable the decentralization of TRs, which can reduce the size of existing TRs or reduce the overall number of TRs. Active zone enclosures are also preferred if distances between TRs and endpoint devices exceed recommended reach limitations of the horizontal cabling. An example of this is where the enterprise building is a large warehouse. Copper cabling would be used within the office from the TR to the work station; however, there might be a small group of users requiring work stations at the shipping dock at the rear of the warehouse, and the distance away from the enterprise TR is greater than 100 meters. In this case, fiber cabling could be used to go from the TR to an active zone enclosure located closer to the small user group. The enclosure contains a network switch, and copper downlinks are used to connect to each of the work stations. If limitations exist that prevent physical access to overhead or underfloor spaces, designers may have to choose passive zone consolidation points instead of active ones.

Another benefit of implementing active zone architectures is that it allows a level of future proofing for an installation. For example, if higher bandwidth requirements are anticipated for a group of workstations (for example, Engineering terminals) in the future, high performance OM3 or OM4 multimode fiber optic trunk cables can be run to the supporting active zone enclosures on Day 1. When it becomes necessary to upgrade the networking speed of these machines, the high performance trunk can be utilized without having to re-run horizontal cabling. Category 6A 10-Gigabit high capacity copper cabling can also be used for horizontal and patch cabling. Video and virtual desktop infrastructures (VDI) are two primary drivers of 10-Gigabit Ethernet connectivity to the workstation in a Day 1 deployment.

As mentioned earlier, Power over Ethernet (PoE) line cards can be used in the chassis-based access switches in the TRs to provide power to devices throughout the building. This is the most usual way of deploying PoE. In those cases where power and cooling resources are at a premium in the TRs, Panduit® DPoE™ Power over Ethernet Systems can be leveraged as midspan power sources in the active zone enclosures. Depending on the particular active equipment being deployed, (for example, switch, midspan Panduit DPoE™ Power over Ethernet Systems, etc.), and the level of uptime and availability required, the zone enclosure may need to be provided with other equipment such as an uninterruptible power supply, etc.

The summary of best practices followed for zone architecture deployments is shown in the following table.

Notes

Table 7 - Zone architecture best practices

| Configuration best practices | ✓ Alignment to Cisco SBA Designs |
|--|---|
| Zone cabling and consolidation enclosures | |
| Select zone cabling architectures for interconnect cabling topologies. | ✓ Zone architectures are most suited for interconnect cabling architectures versus cross-connect. |
| Select zone consolidation enclosures that provide modularity and scale-up capabilities. | ✓ Panduit PanZone® Enclosures are completely modular, accepting Mini-Com® Patch Panels and Modules for STP and UTP, fiber optic, and audio/video applications. In ceiling enclosures are designed to accept up to 8 RU standard 19" passive connectivity or 2 RU of active equipment and 6 RU of passive connectivity. |
| Zone enclosures must include appropriate accessories to ensure proper bend radius control and cable routing flexibility. | ✓ Panduit PanZone® In Ceiling Enclosures accept QuickNet™, Opticom®, and Mini-Com® Patch Panels and can utilize Open-Access™ or Patchlink™ Horizontal Cable Managers to facilitate proper bend radius control. Additional accessories include Tak-Ty® and Tak-Tape™ Hook & Loop products for cable bundle organization. |
| Use appropriate media type based on requirements. | ✓ TX6A™ 10Gig™ UTP Horizontal Cabling with MaTriX Technology can be used to connect TRs and zone consolidation points up to 100 meters apart. If further distances are required, an active switch could be used in an active zone enclosure with Opti-Core® 10Gig™ OM3 or OM4 Horizontal Cables from zone consolidation points to TRs at up to 300 meters. |
| Choose active versus passive zone enclosure strategies based on requirements. | ✓ In general, passive zone consolidation points are best when TR real estate is not a concern and zone enclosures can be easily accessed on the office floor. Active zone points can extend the reach of TRs and save on valuable TR real estate. |
| Ensure proper physical security. | ✓ All zone enclosures can be physically secured with lock and key. |
| The zone enclosures should service an appropriate area and array of devices. | ✓ There is great flexibility in terms of the number of zone enclosures and devices an organization can host on the office floor. Administrators are limited only by the number of RUs available in zone enclosures that can host passive and active components. Standards call out a maximum area of 335 sq. meters (3600 sq. ft.) for each zone enclosure service area. |
| Select zone enclosures to meet local building codes and requirements. | ✓ Panduit in-ceiling and in-floor zone enclosures meet UL 2043 for Plenum use. |

TR-to-Work-Area Pathways

Many of the best practices identified in the TR pathways section are also applicable to the pathways in the office space. The key principle is that these are physically converged pathways because separate pathways are not required to segregate building system cabling from network cabling. Under the raised floor, the GridRunner™ Underfloor Cable Routing System provides a flexible and scalable pathway for cabling. Overhead, the Wyr-Grid® Cable Tray System provides

the best characteristics of ladder racks and wire baskets. Another option to cable management overhead and underfloor is to use the Panduit® J-Pro™ Cable Support System, which provides similar functionality for lower cable counts. These converged pathways run both Ethernet cabling to the enterprise equipment such as laptops, desktops, and IP phones, and fieldbus cabling to the lighting, HVAC, energy, access control, and security systems.

GridRunner™ System Based Pathway

Figure 22 illustrates the pathway architecture of the enterprise office floors using the GridRunner™ System. Larger channels form a trunk pathway, which carries thicker bundles of bulk cabling from the TRs out to the PanZone® floor mounted zone enclosure. In this reference design building, 21 in. x 4 in. (533 mm x 102 mm) GridRunner™ System channels are necessary for the underfloor trunk because these channels must support over 400 copper networking cables when in the proximity of the TRs.

Under the raised floor, smaller pathway channels form branches that are placed perpendicular to the trunk pathways and extend to zone consolidation points in the cubicle, or workstation areas. This allows all devices throughout the building to easily reach zone enclosures and results in an efficient and cost effective zone architecture.

The GridRunner™ System could be used as the pathway solution to the end user node. However, a more cost efficient pathway solution can be deployed when only a few cables are installed. Figure 22 shows use of the J-Pro™ Cable Support System that is attached to the raised floor supports at regular intervals.

- ➔ Cable routing
- A** GridRunner™ System - 21 in. x 4 in. x 48 in. (533 mm x 100 mm x 1219 mm)
- B** GridRunner™ Universal Intersection – 22.62 in. x 22.62 in. (575 mm x 575 mm)
- C** GridRunner™ System - 12 in. x 4 in. x 24 in. (305 mm x 100 mm x 610 mm)
- D** GridRunner™ System - 12 in. x 4 in. x 48 in. (305 mm x 100 mm x 1219 mm)
- E** PanZone® Underfloor Enclosure – 13.91 in. x 12.19 in. x 3.54 in. (353.2 mm x 309.6 mm x 89.8 mm)
- F** J-Pro™ Cable Support System

Figure 22 - Panduit® GridRunner™ System under enterprise office floor

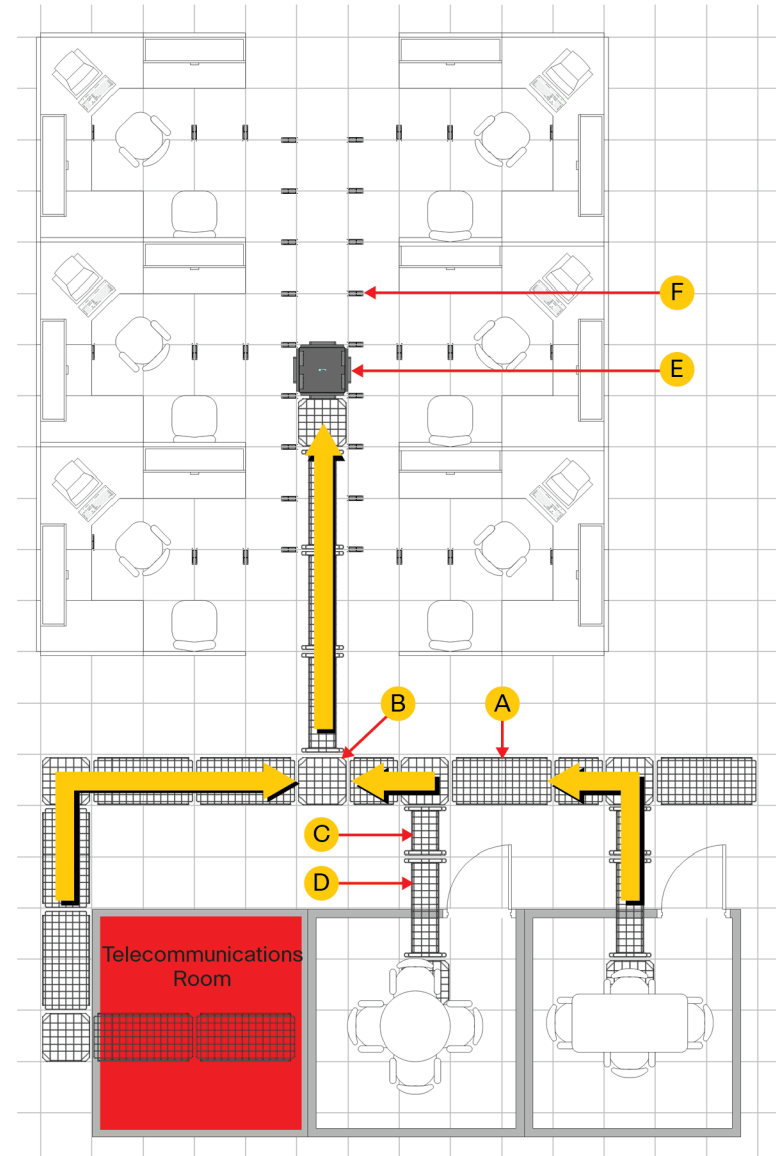

Figure 23 shows a rendering of the layout of the enterprise floor mounted zone enclosure together with pathway and cable leading to the work area typical of that shown in Figure 22. Managed cable bundles come from the TR and are routed to the floor mounted zone enclosure. The patching fields within the enclosure have zone cords that lead to the individual work stations. Cabling to individual or small groups of work stations is routed, secured, and protected using Panduit J-Pro™ J hooks that are attached to the mounting posts for the raised floor. Each work station is fed using the appropriate number of cables (two at minimum per ANSI/TIA-568-C.1). These cables are routed through apertures in the raised floor sections, managed using Panduit Hook and Loop cable ties and secured to vertical supports within the modular furniture.

Figure 23 - Rendering of the enterprise office floor area



Wyr-Grid® System Based Pathway

Alternatively, the same type of approach can be followed where an overhead pathway solution is deployed. Smaller 12 in. (305 mm) wide Wyr-Grid® System channels with 4 in. (102 mm) sidewalls could be used in the drop ceiling because less connectivity is required overhead.

J-Pro™ Cable Support System Based Pathway

Figure 24 illustrates a further option for pathways in the dropped ceiling and raised floor using the J-Pro™ Cable Support System. This system provides a complete horizontal and vertical 1 in. (25.4 mm) bend radius control that helps prevent degradation of cable performance. These pre-riveted assemblies allow for a wide range of mounting configurations including attachment to walls, ceilings, beams, threaded rods, drop wires, and underfloor supports. The wide cable support base also prevents pinch points that could cause damage to cables. These can be used in conjunction with Tak-Ty® Cable Ties to retain the cable bundles.

Figure 24 - Cross sectional view of underfloor and overhead pathway elements

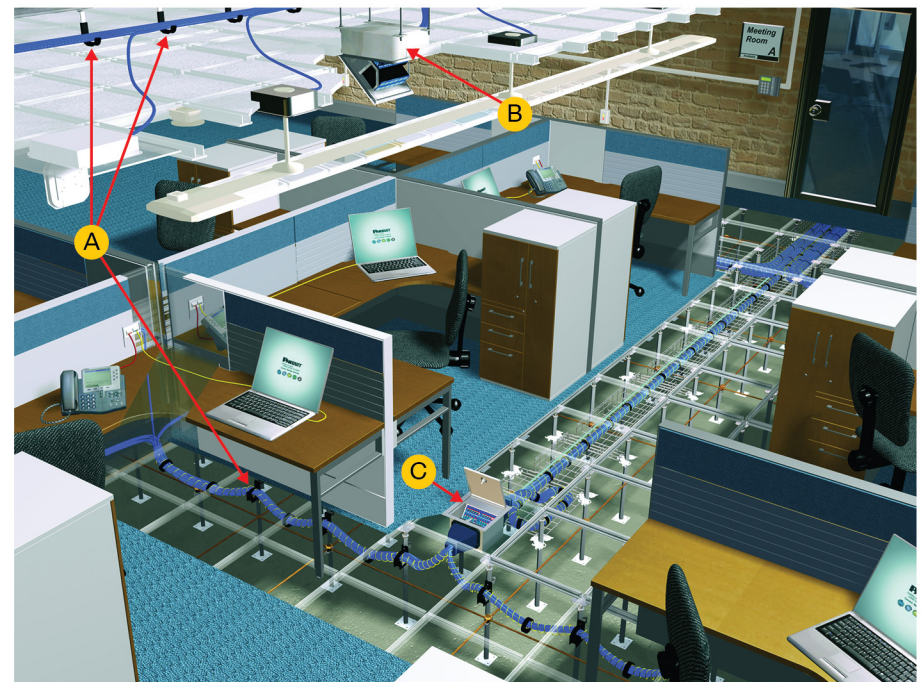

- A** J-Pro™ Cable Support System
- B** PanZone® In-Ceiling Enclosure
- C** PanZone® Enterprise In-Floor Enclosure

The GridRunner™, Wyr-Grid®, and J-Pro™ Systems can be used separately or together to produce an efficient hybrid system. The following are pathway implementation considerations.

- The J-Pro™ System can effectively manage up to 115 Category 6A or 210 Category 6 copper cables. GridRunner™ and Wyr-Grid® Systems can accommodate hundreds of additional cables.
- All pathways can route armored fiber optic trunk cabling that is typically run throughout buildings. However, GridRunner™ and Wyr-Grid® Systems can accommodate higher counts of these trunk cables.
- A hybrid pathway solution can also be used that mixes the GridRunner™ System, Wyr-Grid® System, and J-Pro™ Cable Support System. GridRunner™ or Wyr-Grid® can be used to form trunk pathways, and J-Pro™ can be used as the branches that extend from the trunks.
- Height restrictions under the raised floor or in the drop ceiling may favor the J-Pro™ System.
- Overhead and underfloor spaces that are very crowded or have a significant number of obstacles may favor the J-Pro™ System.
- Though speed to deployment is a benefit of all Panduit pathways, the J-Pro™ System typically can be implemented in the least time.
- All systems are suitable for use in air handling spaces.
- If following a tiered pathway approach is desirable, GridRunner™ and Wyr-Grid® Systems make a good choice.

Work Station Pathway Solutions

Another type of enterprise class pathway is necessary to route cabling from the zone consolidation enclosures under the raised floor or overhead to the workstation areas. Panduit® Pan-Way® Non-Metallic Surface Raceways, depicted in Figure 25, are available in single channel and multi-channel versions, providing maximum flexibility for routing, protecting, concealing, and terminating high performance copper, voice, video, fiber optic, power, and fieldbus cabling. They are aesthetically pleasing, lightweight, tamper resistant, and offer bend radius control fittings. Using Panduit® surface raceway products increases safety benefits, discourages unauthorized access, and protects sensitive cabling from accidental damage and physical contact with electrical wiring. These raceways also provide a variety of choices when selecting data and power terminations, accept NEMA standard 70mm faceplates, and work with all Panduit Mini-Com® Modules for a complete array of connectivity possibilities. Pan-Way® Surface Mount Outlet Boxes are also available to support both communications and power applications.

Pan-Way® Surface Raceway Systems are designed with attention to form as well as function, allow for moves, additions and changes for future upgrades, and are aesthetically pleasing to merge with any décor.

The following table provides a summary of best practices for enterprise pathways.

Figure 25 - Panduit Raceway Systems to workstation areas

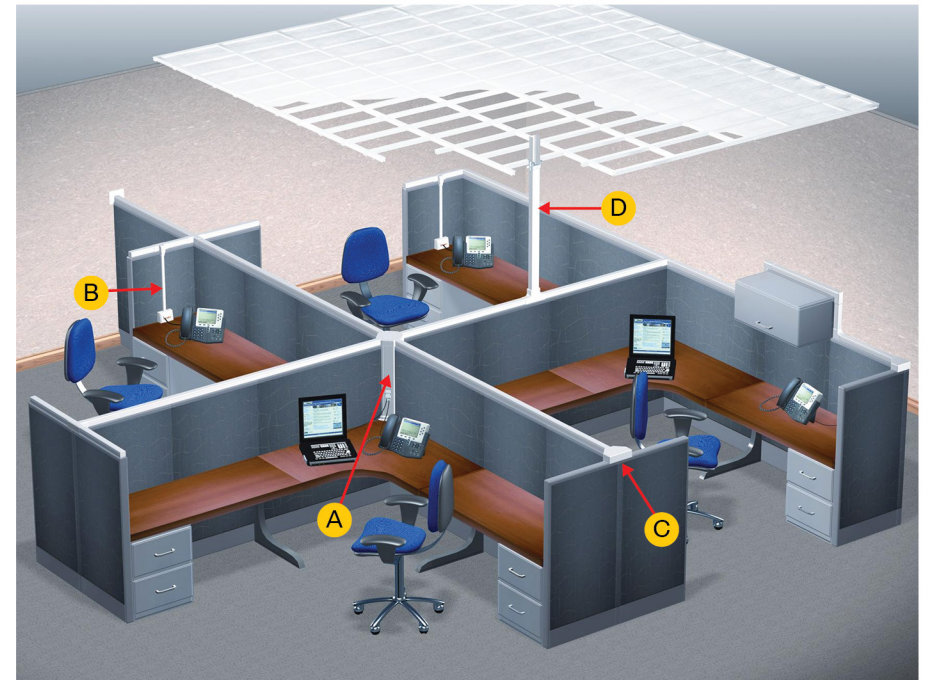

- A** Pan-Way® Office Furniture Raceway System – Corner Raceway
- B** Pan-Way® Office Furniture Raceway System – Vertical Raceway
- C** Pan-Way® Office Raceway Fittings – Two Cubicle Drop Fitting
- D** Pan-Way® Office Raceway Fittings – Communication Pole

Table 8 - TR-to-work-area pathways best practices

| Configuration best practices | ✓ Alignment to Cisco SBA Designs |
|---|--|
| Office space pathways | |
| Use pathways for proper protection of cabling between the data center, TRs, and zone consolidation enclosures. | ✓ Pathways are used from end-to-end in this reference building. Copper, fiber optic, and fieldbus cabling can run in converged Wyr-Grid® Systems, FiberRunner® Systems, GridRunner™ Systems, and J-Pro™ Cable Support Systems. At the workstations, Pan-Way® Office Furniture Raceway Systems are leveraged. |
| When mixing copper and fiber optic cabling in a shared pathway, steps must be taken to effectively manage and separate the disparate cable bundles. | ✓ Since copper and fiber optic cabling are routed in shared pathways, Tak-Ty® Hook & Loop Cable Ties are used to keep the disparate cable bundles merged to the opposite edges of the pathways. |
| Use different pathways to keep adequate separation between copper and power cabling. | ✓ Power cables and copper cables must be kept separated because of noise considerations. |
| Choose the appropriate pathway based on design criteria. | ✓ Pathway selection depends heavily on cable counts, types of cables to be routed, size and organization of overhead and underfloor spaces, number of obstacles that must be routed around in the building spaces, speed to deployment, cost, and the need for routing in air handling spaces. |
| Maintain adequate distances between pathways and premise ceiling or slab floor in overhead and underfloor applications, respectively. | ✓ Maintaining an adequate space around pathways ensures simpler moves, adds, and changes in the future. |
| Pathways made of metallic material must form a proper mechanical bond ensuring electrical continuity throughout the system. | ✓ Wyr-Grid® System and GridRunner™ System automatically create electrical continuity during installation without the need for jumper wires, saving not only installation cost and time, but also ensuring against accidental discontinuities during both the initial construction and future renovations. |
| Provide adequate room in pathways for future expansion. | ✓ Pathways have been sized to ensure a best practice channel fill rate of less than 50%. |
| Configuration should allow for simple moves, adds, and changes. | ✓ Snap-on components in Wyr-Grid® System and GridRunner™ System eliminate or minimize the need for many tools for assembly. Level and directional changes are also easy to accommodate with all pathway systems for working around obstructions. |
| Ensure proper protection for cabling into pathways. | ✓ Bend radius control is maintained with all systems to protect against signal loss due to excessive cable bends. Spill out accessories are provided that ensure bend radius control for entering and exiting the pathways. |

Endpoints

This guide has presented a wide variety of endpoints, which are summarized here.

- **Endpoints such as workstations, laptops, IP phones, and printers**—At the client workstation endpoints, Pan-Way® Snap-On Faceplates mount directly to Cove, TG-70, T-70/Twin-70, Pan-Way® Fast-Snap™ Boxes, and Pan-Pole™ Power and Communication Poles, and install faster than conventional screw-on faceplates. They install without the use of screws, providing faster installation and superior aesthetics. The copper patch cord connections from the outlet to the end point can be deployed with greater assurance of security by using the physical security products—the Jack Block Out and Plug Lock-in solutions described in the “Telecommunications Room Deployment” section. While this reference architecture focuses on deployments of PC-based workstations, it is entirely appropriate for developing computing technologies that make use of thin client workstations in VDI deployments.
- **Building automation system devices such as IP surveillance cameras, and physical access gateways**—When dealing with BAS devices, there are often some that must be mounted on the walls or other locations throughout the building that are easily accessible by end users. It is critical that these devices be protected from tampering and only accessible to authorized personnel. In these cases, Panduit® PanZone® Active Wall Mount Enclosures and Pan-Way® Surface Raceway Systems can provide the necessary physical security and protection of cabling and equipment. These solutions provide an aesthetically pleasing profile, tamper resistant designs to prevent unauthorized access, fully compliant bend radius control fittings to ensure maximum cable performance, and ease of installation, modification, and additions for the overall lowest installed cost.
- **Wireless access points that reside in zone enclosures in the drop ceiling**—Modern wireless access points are often installed in locked enclosures for security and easy access for commissioning. Wall mount options are also available in situations where a ceiling cannot be used. Another advantage of a wireless access point enclosure is for any environment where accessing an area above the ceiling would result in distribution of unwanted dust or contamination such as a health care or laboratory environment.

These endpoints are discussed in more detail in the “Additional Physical Infrastructure Elements” section.

Additional Physical Infrastructure Elements

Grounding and Bonding

Supplementing the electrical power system ground with a telecommunications bonding network improves both personnel safety and the reliability of network equipment by providing additional paths back to the source for fault currents and by promoting electric potential equalization.

There are five guidelines for the construction of a telecommunications bonding system that achieve these objectives. They are:

- Provide electrostatic discharge (ESD) protection
- Bond equipment to the racks/cabinets
- Ensure that racks/cabinets have electrical continuity
- Bond racks/cabinets to the Telecommunications Grounding Busbar (TGB), and the TGB to the PDU or electrical panel
- Bond all of the TGBs in the building together to a Telecommunications Main Grounding Busbar (TMGB) at the service entrance, and bond the TMGB to the ground bar in the Electrical Entrance Facility

The Panduit® StructuredGround™ Grounding System facilitates the attainment of these guidelines and complies with all applicable industry standards including the following:

- **TIA-607-B**—Generic Telecommunications Bonding and Grounding (Earthing) for Customer Premises
- **NECA/BICSI-607**—Telecommunications Bonding and Grounding Planning and Installation Methods for Commercial Buildings
- **IEEE Std. 1100-2005**—IEEE Recommended Practice for Powering and Grounding Electronic Equipment (IEEE Emerald Book)

The following figure provides a graphical overview of the Panduit® StructuredGround™ Grounding System elements and how a sample rack and its associated IT equipment are properly grounded using these elements.

Figure 26 - Grounding and bonding in TRs

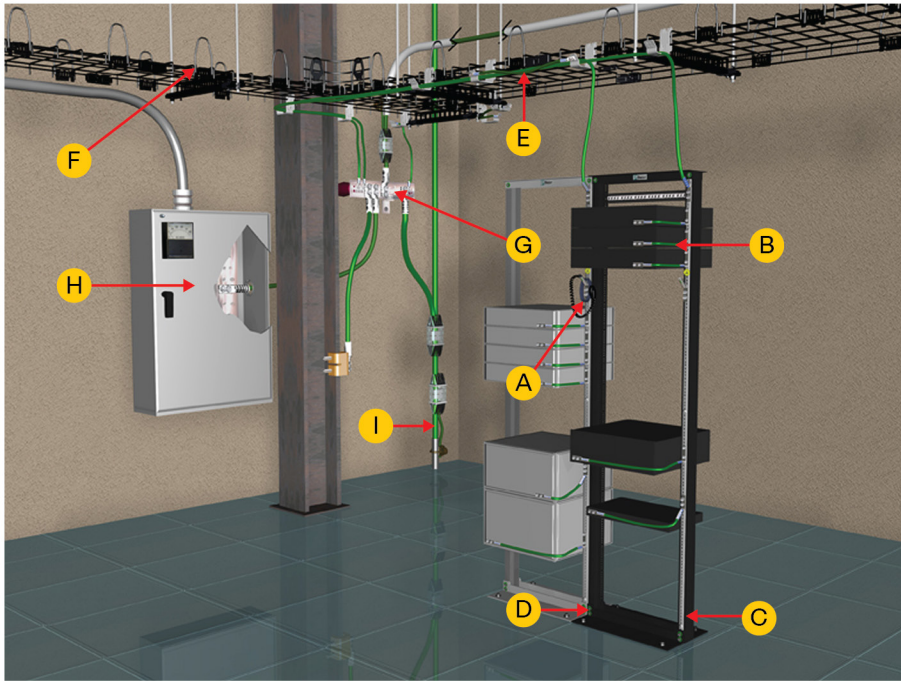

- A Electrostatic discharge (ESD) protection wrist strap
- B Equipment jumper kit
- C Rack grounding strip kit
- D Grounding washers
- E Wyr-Grid® Pathway System
- F Telecommunications grounding busbar
- G Main electrical panel serving equipment
- H Telecommunications bonding backbone (TBB)
- I Grounding washers

Identification

All physical infrastructure elements within the *Cisco SBA—Borderless Networks LAN Design Overview* and the building automation system devices discussed in this guide should be properly identified. Proper labeling provides two very important benefits: determining locations of components and defining system connections. It is this determining and defining that allows quick, clear communication required to accurately install, maintain, and repair critical infrastructure components resulting in efficient and consistent data center and network environment maintenance. The relevant standards used to define this strategy are TIA-942, TIA/EIA-606A, and TIA/EIA-606A, Addendum 1.

Following these standards provides maximum flexibility and scalability for the infrastructure labeling, and simplifies moves, adds, and changes. A best practice is to create labels by using a mechanical device, such as a thermal transfer desktop or hand-held printer, which ensures legend legibility and which uses durable labeling materials that withstand exposure to temperature, humidity, abrasion, or chemicals.

In the data center domain, component locations are typically determined by using an X-Y coordinate system that is based on the floor tile grid system. Using alphabetic characters on one axis of the room and numerical characters on the other axis, a series of alphanumeric designations is established for each floor tile in the data center space. This same strategy can be leveraged in the TRs displayed in this reference guide because a raised floor has been installed throughout the building. However, if a raised floor has not been deployed, the rack row and position of the rack in the row can be used to define the location in a TR.

You can follow the labeling strategies defined in the TIA standard cited in this section for equipment in the TR. For example, all cabinets and racks are clearly identified through labels applied to the top and bottom at both the front and rear of the cabinet or rack.

You should also label all zone enclosures properly throughout the building. This provides a quick method of locating connections to zone enclosures by using information on far end cables. These labels should be visible whether or not doors are closed or opened on the enclosures.

In this guide example, passive and active equipment in all cabinets, racks, and zone enclosures are also identified. For example, the designation for the rack mounted patch panel is composed of the location of the rack followed by a two-digit number that represents the rack unit number (RU) where the

top-left mounting screw lands. Using the RU method provides administrators with greater flexibility because it allows for panels and equipment to be added or removed later without disrupting the designation of panel identifiers.

Port identifiers define the connectivity of cabling throughout the organization. The numbering sequence proceeds from left to right and top to bottom for all ports on a patch panel. Depending on requirements, either continuous tape or die-cut labels can be used to create port identifiers. Die-cut labels save time and effort by eliminating the need for cutting between labels or manually aligning legends with ports.

Cables are identified with information that defines the connection between the near end panel connection and the far end panel connection between two end-points throughout the organization's environment. A near-end connection identifier consists of the cabinet, rack, or zone enclosure location; panel location; and port location. The far-end connection identifier consists of the cabinet, rack, or zone enclosure location; panel location; and port location.

Patch cord labels are identified with information that defines the connection between the near-end patch panel front connections and the far-end patch panel front connections or equipment connections. A near-end connection identifier consists of the cabinet, rack, or zone enclosure location; panel location; and port location. The far-end connection identifier consists of the cabinet, rack, or zone enclosure location; panel location; and port location.

Self-laminating labels are ideal for cable and patch cord identification. Self-laminating labels are designed with a white or colored printable area and a clear tail. These wraparound labels are easy to install and allow the legend to be viewed from any angle. Self-laminating labels are available in both standard adhesive style and Turn-Tell®, non-adhesive, rotating style. Panduit Turn-Tell® self-laminating labels can be slid down a cable or rotated after installation. This allows the label to be temporarily moved out of position while re-terminating a cable.

In the office area, each individual telecommunications outlet/connector should be labeled with the horizontal link identifier. The labeling should appear on the connector or faceplate in a way that clearly identifies the origination of the horizontal link.

Labeling of the grounding and bonding system within a TR involves the identification of the main grounding busbar, grounding busbars, conductors connecting busbars, conductors connecting devices to busbars, and equalizing conductors.

Physical Infrastructure Manager

This reference guide has mentioned the primary tool used to manage this converged environment, the Panduit Physical Infrastructure Manager™ (PIM™) Software Platform. The "Alignment of Logical Architecture to Physical Infrastructure" section discusses the management of the physical elements using Panduit PViQ™ Patch Panels, Intelligence Modules, PViQ™ Copper Interconnect Patch Cords, PViQ™ Power Outlet Units, and the PIM™ Software Platform.

The PIM™ Software Platform offers visibility into:

- Unauthorized patch field changes
- Potential physical network security breaches
- Root cause analysis of physical network problems
- Moves, adds, and changes (MACs)
- Capacity limits
- Power consumption of active equipment
- Temperature and humidity threshold alerts
- Underutilized assets and resources

This type of visibility adds tremendous value to the design proposed in this reference guide. For example, installing PViQ™ Patch Panels, Intelligence Modules, and PViQ™ Patch Cords in the TRs enables the responsible network operator to perform root cause analysis of physical network problems. Figure 27 illustrates a visual notification within the PIM™ Software that indicates an IP surveillance camera has gone offline. PIM™ Software also identifies the exact physical location of that camera, which in this case is a TR. The security of the TR could be compromised without a functioning IP camera so a network operator would most likely take immediate action by deploying a technician to that TR to further investigate and resolve the issue. From the IT center, the operator can continue to monitor PIM™ software to confirm if the technician successfully resolved the issue by bringing the IP camera back online. This same type of notification would also be seen if a technician has incorrectly performed a patching operation within a TR. Along with the 24/7 monitoring of the enterprise, this functionality greatly reduces mean time to repair (MTTR), helps enforce service-level agreements (SLAs), and streamlines audits.

Figure 27 - PIM™ software notification of connectivity problem

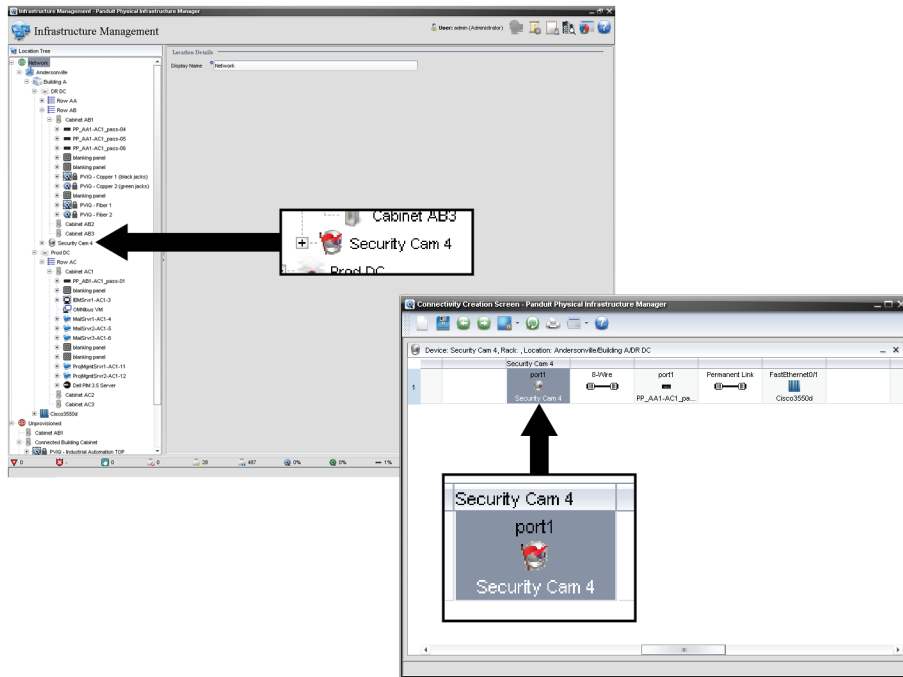

PIM™ Software is invaluable for reducing the time from receipt of asset to deployment, and it allows you to reclaim, repurpose and redeploy assets effectively. Unlike manual record keeping, PIM™ software centralizes the collection and representation of a rich set of asset attributes, such as connectivity, space/port availability, and power/environmental parameters such as humidity, temperature, etc., to ensure that the physical infrastructure supports mission-critical applications.

Power over Ethernet (PoE)

The use of Power over Ethernet (PoE) can provide many advantages to a network deployment. These advantages include the following:

- Running a conventional power outlet to equipment is not required
- Distributing power usage more uniformly throughout the facility
- Saving valuable rack space and allowing for deployment in space-constrained locations
- Enabling network modularity and scalability to grow the network as needed
- Providing redundant powering to reduce risk and diminish downtime
- Simplifying installations by leaving switch hardware untouched
- Reducing heat in data centers or closets with energy efficient components

PoE can be used for a variety of applications such as providing a power source for IP security cameras, IP telephony, and IP mobility through wireless access points, shown schematically in the following figure.

Figure 28 - Schematic of structured cabling in the work area

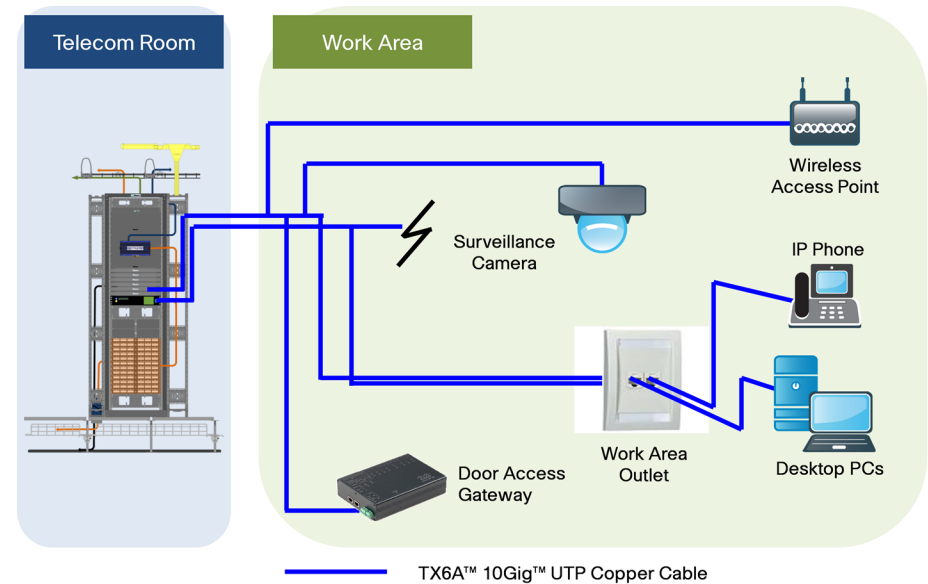

Audio/Video (AV) Systems

The example organization in this reference guide is entirely typical of those seen throughout the world where there are a supporting number of conference rooms within an open office area. The conference rooms are varied in size and provisioned accordingly with equipment such as audio systems for teleconferencing, high-definition multimedia projectors, video player systems, etc.

In order to accommodate differing equipment throughout the organization, the cabling and connectivity system for audio/video (AV) systems must be both flexible and support different connector types. Panduit Audio Video Solutions offer a wide variety of faceplates that are typically, but not exclusively mounted in the wall to provide cabling outlets. Faceplate frames are more frequently mounted into the conference room tables and provide convenient access to users to establish connections to required AV services. The faceplate frames support inserts, which in turn support single or double width Mini-Com® modules. Available Mini-Com® modules include RJ45 jacks, RCA connectors, USB modules, HDMI modules, BNC co-ax modules, S-Video, etc. The following figure shows an example of double-gang faceplate frame fitted with two module wide flat inserts and then populated with a variety of single and double width modules.

Figure 29 - Panduit audio video solutions



Wireless Access Points and Enclosures

The deployment of wireless capability in an organization has become a necessity for modern business communications. Wireless can be separated into three functional areas, each with a specific role in the connected building.

- Wireless for data communications
- Wireless for mobile telephone communications
- Wireless for safety systems and personnel

Wireless for Data Communications

The AP device is typically made of plastic or metal and may have attachment points for antennas. One of the concerns of AP users is that mounting the device directly on a ceiling or wall can expose the AP to pilfering or damage, therefore it is common to have these AP devices installed in a secure lockable enclosure. Some AP enclosures are designed for either a ceiling mount or wall mount. A suspended ceiling is often the location of choice for the AP enclosure. These enclosures are designed to replace a conventional 2' x 2' ceiling tile and offer aesthetics to insure the enclosure and AP are not obtrusive in the environment. When a wall mount is used, surface raceway can be run to the enclosure because running cable behind a finished wall can be difficult.

Panduit offers a full range of these enclosures to fit the variety of AP devices from Cisco.

The 19" wide rack mountable switch or AP controller that communicates to the AP can be located in the TR, remotely located in a zone enclosure that could mount in the ceiling of an office building or on a wall if a TR location is full or not directly accessible by the AP cabling. Most commonly, it can also be located in the data center. The following illustrates the various wireless access point connections to the TR.

Figure 30 - Wireless access point connections to the TR

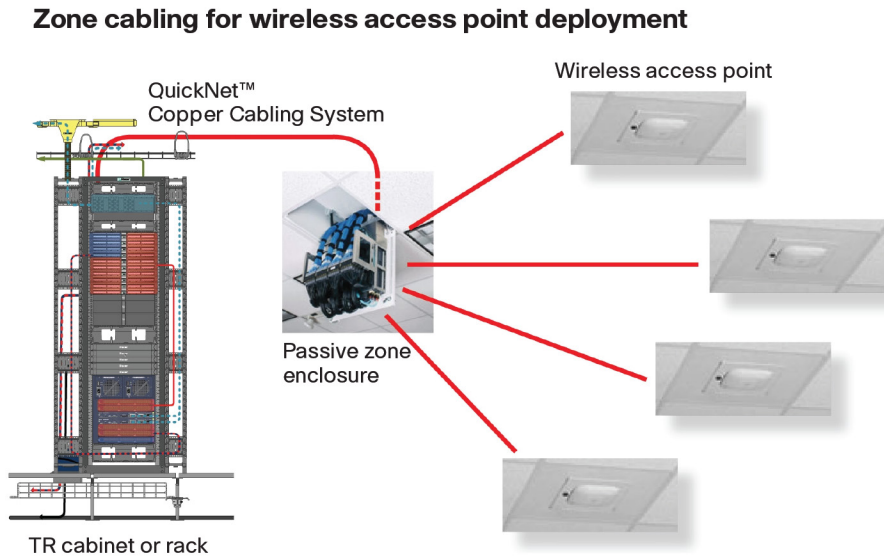
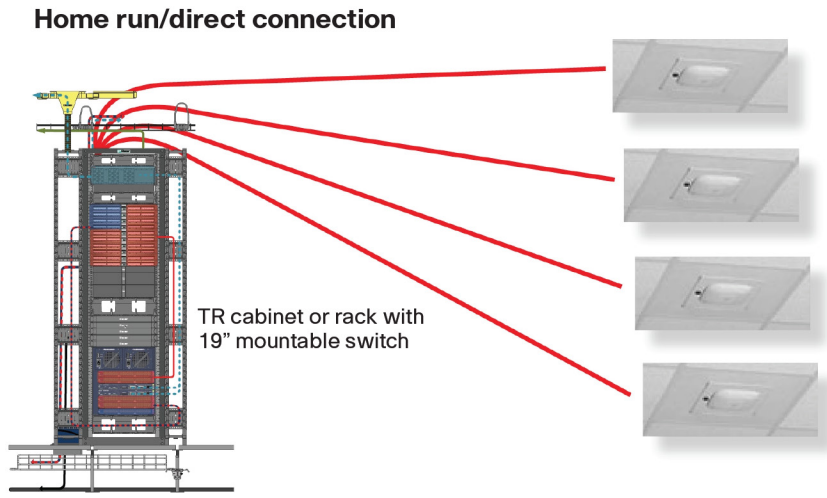

Wireless for Mobile Telephone Communications

Mobile telephone communications is another area of the organization where wireless connectivity is used. Common cell phone carriers often cannot transmit their signals through the wall of many buildings. In this case, repeaters are often installed in buildings to allow connectivity to the carrier's wireless signals or in some cases the physical infrastructure is used to connect the cell phone signals to the internet for connectivity.

The networking architecture described in this guide provides future-proofing against the support of wireless operator signals over enterprise Wi-Fi networks. Today, there are a number of wireless devices that can support operation over either a wireless operator network or the organization's Wi-Fi network. In the future will come the technology and standards that will enable a mobile device to seamlessly alternate between both networks, and this will drive demand for ever more traffic supported on the enterprise network. This increase in traffic will drive demand for still higher data rates. The development of higher data rate wireless access points is evolving at a rapid pace, as evidenced by the release of successive versions of IEEE 802.11.

Wireless for Safety Systems and Personnel

Safety personnel who are responding to an emergency situation in a building may have difficulty communicating with each other in some buildings and in some emergency circumstances. Special repeaters are often installed in large buildings that allow emergency personnel to communicate and offer some degree of operation with an uninterruptable power supply, in case of a power outage.

Panzone Enclosures

Panduit provides a comprehensive line of wireless access point enclosures for indoor, industrial, and outdoor wireless LAN applications. The complete line of PanZone® Wireless Access Point Enclosures accommodates a full range of wireless access points from Cisco Systems. PanZone® Wireless enclosures provide an additional level of security for your wireless LAN by protecting wireless access points from tampering, vandalism, theft, and harsh environments. In addition, Panduit expertise in network infrastructure provides peace of mind that your wireless network will transition seamlessly onto your wired network.

Figure 31 illustrates various Panduit PanZone® Wireless Access Point Enclosures.

PanZone® Wireless Access Point Enclosures feature the following:

- Enclosures specifically designed for use with Cisco Aironet 1040, 1130, 1200, 1230, 1240, and 1250 Series Wireless Access Points with others in development
- Lockable enclosure protects against tampering, vandalism, and theft
- Connectivity accessory kit (included) provides 2-position surface mount box, MINI-COM® TX6™ PLUS Jack Module, TX6™ PLUS Patch Cord and grounding cable; there is also a shielded connectivity accessory kit available
- Optional ceiling bracket kit allows a wireless access point to be mounted in a ceiling for design flexibility for optimum wireless coverage. Choose 2' x 2' or frame style ceiling brackets

Figure 31 - Panduit PanZone® wireless access point enclosures



Surveillance Cameras

Video surveillance can be provided using IP cameras in conjunction with IP video surveillance software. Cisco video surveillance IP cameras are feature-rich digital cameras that enable surveillance in a wide variety of environments. Available in standard and high definition, box and dome, wired and wireless, and stationary and pan-tilt-zoom (PTZ) versions, the cameras support MPEG-4 and H.264 and offer efficient network utilization while providing high-quality video.

Medianet Support

As part of Cisco's wider business video strategy to support medianet architecture, the Cisco Video Surveillance 4500 Series IP cameras can now be automatically configured on an Ethernet switch port, dramatically reducing the time and expertise needed to deploy cameras.

IP-based video surveillance cameras deployed throughout the example enterprise in this guide are connected to the IP network through copper cabling and are connected to the closest TR. All camera data is available to the management software and capable of being reviewed by security staff.

The following figure shows an example of how the logical connections for the IP-based surveillance system are made. The access layer in the figure is physically realized in the edge switches used in the TRs. The Distribution and Core layers are located within the example enterprise data center.

Figure 32 - Logical connection diagram for the video surveillance system

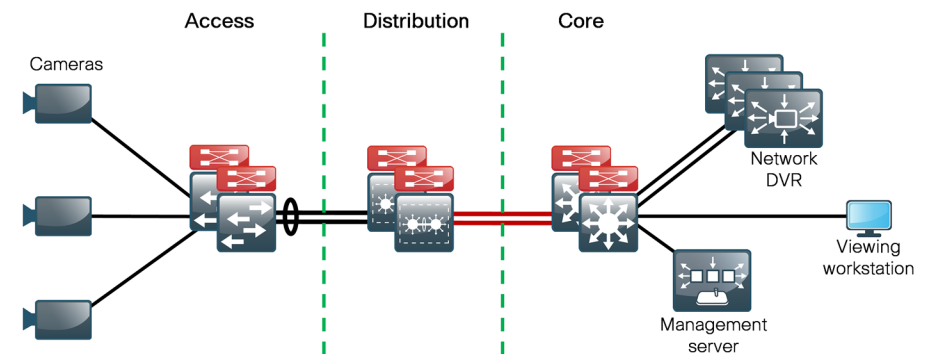

Voice over IP Phones

Voice over IP (VoIP) enables secure, reliable voice calls over the network. IP telephony transmits voice communications over the network using open, standards-based Internet Protocol. VoIP provides a way to extend consistent voice communications services to all employees in their workspaces—on the main campus, at branch offices, remote, or mobile.

Cisco IP telephony solutions are an integral part of Cisco Unified Communications, which unify voice, video, data, and mobile applications on fixed and mobile networks. Employees can communicate with each other using almost any media, device, or operating system.

Using your network as the platform, your organization can gain the inherent benefits of a converged network for transport and interconnection. IP telephony makes it easier to:

- Provide highly secure, reliable, scalable communications that take advantage of your LAN and WAN
- Improve employee flexibility and productivity with the full range of Cisco Unified Communications and third-party applications
- Take advantage of a wide range of Session Initiation Protocol (SIP)-based capabilities

An example of a Cisco VoIP phone is shown in Figure 33. The phone is directly connected to the structured cabling entry point, (i.e. a wall mounted outlet at the work area, using a conventional copper patch cord). In most cases the phone is powered directly by a PoE-based source or may be powered using a conventional local power supply connected to the utility. In addition, many of the phone types provide an additional output RJ45 port that can be used to support data traffic to and from a work station, such as a desktop or laptop computer.

Figure 33 - Example Cisco VoIP phone



Door Access

Access control systems have become increasingly popular as a means to control access of persons to buildings. They are used to control admission to areas, rooms or buildings, and can be operated in a tiered fashion so that persons with, for example, a higher level of clearance or permission can be allowed access to more restricted areas. Access control systems can form the basis for access schedules, (for example, no one is allowed access to the premises over the weekend) and also allow tracking of individuals throughout a building.

There are many sources of identity for an individual including RFID badges, government issued IDs, handprints, fingerprints, retina scans, etc. The access control systems that use these forms of identity are more secure than traditional key and lock systems, which cannot be disabled when lost or stolen. No matter the type of identity, authentication takes one of three forms: something you know (PIN), something you have (proximity card or badge), or something you are (fingerprint or retina scan).

Previous electronic access control systems were based on local door access control panels being linked to a central controller or access panel using an RS485 type serial data link. Each local door access control panel requires its own source of power, usually a separate piece of hardware connected to the utility supply.

The following figure shows a modern day IP-based access control system where the Cisco Physical Access Gateway is located close to the door under access control. The Cisco Physical Access Gateway can be powered using a PoE-based switch or midspan device, or alternatively, can still use the utility supply.

Figure 34 - Cisco access control deployment architecture

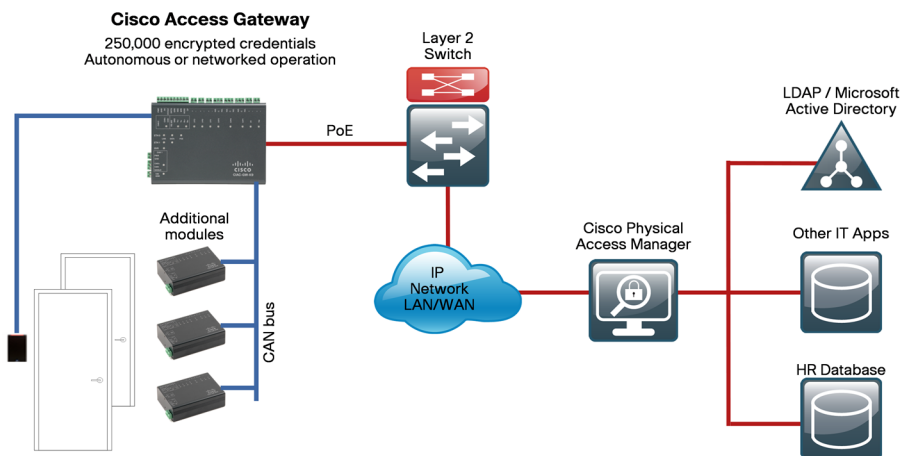

The Cisco Physical Access Gateway is the primary means for the Cisco Physical Access Control solution to connect door hardware, such as locks and readers, to the IP network. One gateway can control up to two doors. The Cisco Physical Access Gateway:

- Offers a distributed architecture to simplify installation of electronic access control
- Uses a PoE switch or external 12 to 24 VDC source
- Enables powering of badge readers and locks/strikes with PoE
- Is directly configurable through a built-in web server
- Eases deployment through server discovery by using network services
- Supports static and dynamic IP addressing
- Supports offline operation to allow doors to function if network connectivity is lost

The following figure shows an example Cisco Physical Access Gateway. The gateway effectively interfaces between the IP network and individual access control devices, including electronic door strike/magnetic lock, request-to-exit motion sensor, door position switch (for example, a contact sensor on the door), access control card reader, and tamper alarms.

Figure 35 - Cisco door access gateway



By connecting reader, input, and output modules to the gateway through a Controller Area Network (CAN) bus, you can add doors, inputs, and outputs without additional Ethernet ports. Other scalability features include the following:

- Holds up to 250,000 credentials in an encrypted cache
- Scales from a single door to thousands at a fixed cost per door
- Requires no additional memory or storage for even the largest deployments

The Cisco Physical Access Gateway also requires no scheduled maintenance, thereby lowering total cost of ownership. Each Cisco Physical Access Gateway in the example enterprise is connected through the structured cabling system to the access layer switch in the closest TR. Data is aggregated from there into the data center either by direct fiber connection or through the IP network LAN or WAN. Also connected to the access control system through the IP network is the Cisco Physical Access Manager, from which records, policies and permissions can be administered. If required, the Cisco Physical Access manager can interface to other IT applications, HR databases and LDAP (Lightweight Directory Access Protocol) Microsoft active directories.

Cisco EnergyWise

In the face of rising energy costs, environmental concerns, and government directives, there is an increased need for sustainable and *green* business IT operations. Methods to measure power consumption in the organization, report it, and manage it are now of great interest to businesses worldwide, with focus being directed towards consolidating energy management into one common platform.

Cisco EnergyWise is an energy management architecture that allows IT operations and facilities to measure and fine-tune power usage to realize significant cost savings. Cisco EnergyWise focuses on reducing power utilization on all devices connected to a Cisco-enabled network, ranging from Power over Ethernet (PoE) devices such as IP phones and wireless access points to IP-enabled equipment such as desktop computers, building, and lighting controllers.

Cisco EnergyWise measures current power consumption, automate and take actions to optimize power levels, and advise how much power is being consumed to demonstrate cost savings. After power consumption is understood, regulation using the Cisco EnergyWise network protocols provides command and control of power usage. Energy consumed per location can easily be found with a realistic view of power consumed per TR, building floor, or campus building. The following figure shows a schematic of the network enabled by Cisco EnergyWise.

Figure 36 - Network enabled by Cisco EnergyWise

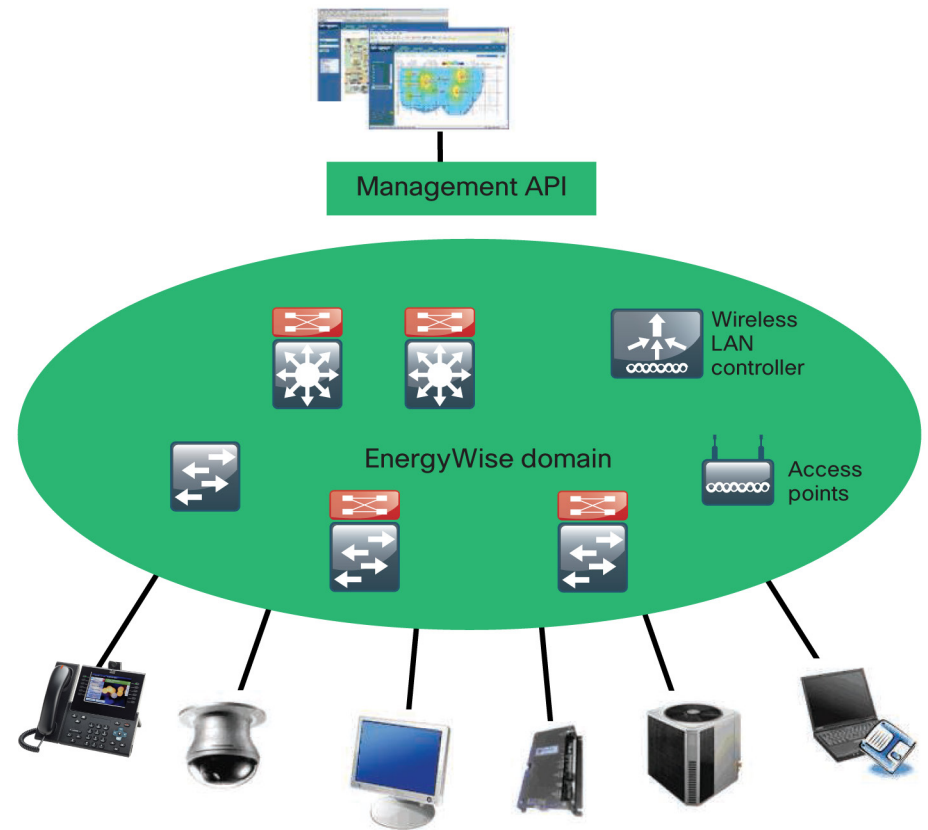

The end points, the cabling infrastructure, and TR design described in this reference architecture would enable Cisco EnergyWise to measure, report, and optimize power consumption throughout the reference building.

Appendix A: Bill of Materials

| Part number | Description |
|-------------|--|
| ACE48 | PanZone® Enterprise In-Floor Enclosure |
| C100X050A8T | Desktop Labeling System – Equipment Labels, Qty. 1 per piece of equipment |
| C200X100YPC | Handheld Labeling System – Cabinet Labels, Qty. 4 per cabinet |
| C300X100APT | Desktop Labeling System – Cabinet Labels, Qty. 4 per cabinet |
| CJ688TGBU | Mini-Com TX6 PLUS Jack Module. Category 6 |
| CLT150F-X4 | Slit Corrugated Loom Tubing |
| CMBRS485OR | Module supplied with 22 AWG min/18 AWG max connector |
| CS1 | Net-Access™ Server Cabinet |
| CPAF1BLY | Angled filler panel, 1 RU |
| CPAF2BLY | Angled filler panel, 2 RU |
| CPATCBL | Transitional cover for angled patch panels that occupies zero rack space |
| CRB6BL | CabRunner™ Overhead Cable Routing System base unit with 6 in. (150mm) high wall |
| DPFP1 | Filler Panel, 1 RU. Dimensions 1.75"H x 19.0"W |
| DPFP4 | Filler panel, 4 RU. Dimensions 6.97"H x 19.0"W |
| DPFP8 | Filler panel, 8 RU. Dimensions 13.97"H x 19.0"W |
| DPOE24UIXG | 24-port UTP 1 GbE 10/100/1000 patch panel supporting IEEE 802.3af-2003 and legacy PoE power protocols. |
| DPOE8S2XG | 8-port STP 10/100/1000 midspan supporting IEEE 802.3af-2003 and legacy PoE protocols. |
| DPOE8KIT | Compact 8 midspan kit includes individual unit, 120 watt power supply, and 15 A power cord |
| DPOEWM8B | Wall mount bracket for DPOE8S2XG |
| DPOEPL8BU | 8-port passive patch panel module |
| DPOESHOLF | 1 RU shelf for DPOE8S2XG |
| DPOEPWRCU | Power system chassis |

| Part number | Description |
|----------------|--|
| DPOEPWRR1250 | 1250-watt power rectifier supplies power for multiple patch panels |
| FAP6WAQDLCZ | Fiber Adapter panel, 6 LC 10-Gig duplex adapters, aqua, zirconia ceramic sleeves |
| FBC2X2YL | 2x2 FiberRunner® System QuikLock™ Coupler |
| FHDEC2X2YL | 2x2 Hinged Channel End Cap Fitting |
| FIDT2X2YL | 1-Port Spill-Out to 1.5" (38 mm) Inside Diameter Corrugated Tubing |
| FODPX24Y | 24-fiber 10-Gig™ 50/125µm (OM3) multimode plenum rated distribution cable |
| FQZO-12-10 | 10-Gig™ 50/125µm (OM4) MM SFQ Series MTP Cassette |
| FRME4 | Opticom® Rack Mount Enclosures. Accepts up to (12) FAP or FMP adapter panels, (1) splice tray holder (FST24H3) and (3) splice trays (FST24). Support up to (96) ST*, (144) SC or (144) FJ® fiber optic terminations. |
| FSPX245-5F***A | 24 Fiber OM3 Female MTP to Female MTP Trunk Cable Assembly with pulling eye |
| FTRBN12 | Threaded rod bracket for Fiber-Duct system |
| FVTHD2X2YL | 2x2 Vertical Tee Fitting |
| FX12D5-5M***Y | 12 Fiber OM3 Female MTP to Female MTP Interconnect Cable Assembly |
| FZE10-10M**Y | LC to LC 10Gig OM4 Multimode Duplex Patch Cord |
| GACB2 | Grounding Hanger Bracket for supporting grounding conductors from wire basket |
| GB2B0306TPI-1 | Telecommunications Grounding Busbar (TGB). ¼" thick x 2" width x 12" length. Tin-plated, copper bar with pre-configured isolators and mounting brackets. |
| GJ6144UH | TEBC kit for bonding racks to TGB. 144 in. length, 6 AWG, green with yellow strips, pre-connectorized on both ends |
| GJ6168UH | TEBC kit for bonding racks to TGB. 168 in. length, 6 AWG, green with yellow strips, pre-connectorized on both ends |
| GJ6192UH | TEBC kit for bonding racks to TGB. 192 in. length, 6 AWG, green with yellow strips, pre-connectorized on both ends |
| GJS660U | Equipment Jumper Kit for grounding Cisco equipment chassis. 6 AWG, green with yellow stripe, pre-connectorized at one end with a 2-hole copper compression lug. |
| GR12X4X24PG | GridRunner™12x4x24 Wire Basket |
| GR12X4X48PG | GridRunner™12x4x48 Wire Basket |

| Part number | Description |
|---------------|---|
| GR21X4X24PG | GridRunner™ 21x4x24 Wire Basket |
| GR21X4X48PG | GridRunner™ 21x4x48 Wire Basket |
| GRBRC4PG | GridRunner™ 4" Bend Radius Control |
| GRCLAMPPG-X | GridRunner™ Pedestal Bracket Clamp (Quantity adjusted from 144 pc to 15 pkg. based on package quantity) |
| GRFWC21PG | GridRunner™ Universal Intersection |
| GRPBPG | GridRunner™ Pedestal Bracket |
| HC2YL6 | 2x2 Snap-On Hinged Cover |
| HDW3/8-KT | 3/8" Stainless Steel Hardware Kit for attaching lugs to TGB |
| HS2X2YL2NM | 2x2 FiberRunner® System Channel |
| JP4UF100-X20 | J Hook with underfloor pedestal support clamp for use with pedestal support up to 1 in. (25.4mm) diameter |
| JP4CM-X20 | J Hook with ceiling mount bracket that has one 3/16 in. (M5), ¼ in. (M6) and 3/8 in. (M10) mounting hole |
| LCC1/0-14AW-X | 2-hole copper compression lug for attaching supplemental bonding grid (SBG) to TGB |
| LS8EQ-KIT | Handheld Labeling System – Printer, Qty. 1 |
| NMF* | Horizontal cable mgr front only; * can be a number 1 – 4 for # RU spaces consumed |
| OFR20**6 | Pan-Way® Office Furniture Raceway |
| OF70**6 | Pan-Way® Office Furniture Raceway System - Corner Raceway Base |
| OFVR5**6 | Pan-Way® Office Furniture Raceway Fittings - Vertical Raceway |
| OFR20CP**8 | Pan-Way® Office Furniture Raceway Fittings - Communication Pole |
| PED6 | Patchrunner™ High Capacity 6.1" (155mm) Dual Hinge Door for 84" High (2134mm) Racks |
| PED8 | Patchrunner™ High Capacity 8.1" (206mm) Dual Hinge Door for 84" High (2134mm) Racks |
| PEV6 | 6" PatchRunner™ enhanced vertical manager |
| PEV8 | 8" PatchRunner™ enhanced vertical manager |
| PSL-DCJB-OR* | Package of ten jack module blockout devices and one removal tool |
| PVQ-EM | PViQ™ Expansion Module |
| PVQ-MIQAPU24 | 24-port Angled UTP modular intelligent patch panel blank |

| Part number | Description |
|----------------|---|
| PVQ-PM | PViQ™ Panel Manager |
| PVQ-PS12VDC-x | PViQ™ Power Supply |
| PZAEWM3 | PanZone® Active Wall Mount Enclosure |
| PZBASE3 | PanZone® Building Automation |
| PZICEA | PanZone® In-Ceiling Enclosure. Accepts up to 2 RU of active network equipment and up to 6 RU of passive product |
| PZICE | PanZone® In-Ceiling Enclosure. Accepts up to 8 RU of standard 19" patch panels |
| PZCPE4F | PanZone® Underfloor Enclosure. Accepts up to 4 fiber adapter panels (FAPs) or 2 QuickNet™ Pre-Terminated MTP* Cassettes. |
| PZWIFIEN | PanZone® Wireless Access Point Enclosure. Accommodates Cisco Aironet 1250 Series Wireless Access Points |
| QAPP24BL | QuickNet™ Angled Patch Panel, 24 Port, 1 RU |
| QAPP48HDBL | QuickNet™ Angled Patch Panel, 48 Port, 1 RU |
| QARBCBCBXX** | QuickNet™ Category 6A Cable Assembly with pre-terminated jack module cassettes on each end (** = specify length in feet) |
| QCPBCBCBXX***N | Plenum, Category 6A, cassette to cassette assembly (** = specify length in feet) |
| QPP24BL | QuickNet™ Flat Patch Panel, 24 Port, 1 RU |
| QPP48HDBL | QuickNet™ Flat Patch Panel, 48 Port, 1 RU |
| QPPBBL | QuickNet™ Patch Panel Blank |
| QZ1B1N3BN30P1 | 3 Phase, 30A, 208V AC Power Outlet Unit |
| QZ1B2G6BN24R1 | 3 Phase, 60A, 208V AC Power Outlet Unit |
| R100X125V1C | Handheld Labeling System—Fiber Patch Cord Labels, Qty. 2 per cord |
| R100X125V1T | Desktop Labeling System—Fiber Cable Labels, Qty. 2 per cord |
| R100X150V1C | Handheld Labeling System—Copper Patch Cord Labels, Qty. 2 per cord |
| R100X150V1T | Desktop Labeling System—Copper Cable Labels, Qty. 2 per cord |
| R100X225V1C | Handheld Labeling System—Power Patch Cord Labels, Qty. 2 per cord |
| R100X225V1T | Desktop Labeling System—Power Cable Labels, Qty. 2 per cord |
| R4P36 | 36" Deep 4 Post Rack |
| RFG*X*SMY | Cool Boot® Raised Floor Air Sealing Grommet |
| RGCBNJ660P22 | Common Bonding Network (CBN) Kit for attaching racks and cabinets to the supplemental bonding grid (SBG). Six AWG green with yellow stripe, pre-connectorized at one end with a two-hole compression lug and includes copper compression tap and mounting hardware. |

| Part number | Description |
|--------------------|--|
| RGS134-1Y | Grounding Strip Kit for Threaded Rails. Used for racks and cabinets with threaded hole equipment mounting rails. |
| RGS134B-1 | Grounding Strip Kit for Cage Nut Rails. Used for racks and cabinets with cage nut equipment mounting rails. |
| T050X000VXC-BK | Handheld Labeling System—Equipment Labels, Qty. 1 per piece of equipment |
| TDP43MY | Desktop Labeling System—Printer, Qty. 1 |
| TLBP1R-V | 1 RU Tool-less blanking panel for round tapped holes |
| TLBP1S-V | 1 RU Tool-less blanking panel for square holes with or without cage nuts |
| TLBP2R-V | 2 RU Tool-less blanking panel for round tapped holes |
| TLBP2S-V | 2 RU Tool-less blanking panel for square holes with or without cage nuts |
| UICMPPA24BLY | 24-port angled patch panel with 6 UICPPL4BL Mini-Com® Ultimate ID™ faceplates |
| UTP6A** | 10 G UTP Patch Cord (** = specify length in feet) |
| WG12BL10 | Wyr-Grid® System 12" Wide Straight Section |
| WGBTMWFBL | Wyr-Grid® System Bottom Waterfall |
| WGCB12BL | Cantilever Bracket |
| WGINTBRC4BL | 4 in. Intersection Bend Radius |
| WGINTSPLBL | Intersection Splice |
| WGSDWL4BL | Wyr-Grid® System 4" Sidewall |
| WGSPL1218BL | Wyr-Grid® System Splice Connector for 12" and 18" width |
| WGTB12BL | Wyr-Grid® System 12" Wide Trapeze Bracket |
| GWMTB12BL | Wyr-Grid® System Wall Mount Termination Bracket |

Appendix B: References

ANSI/TIA-568-C.1, *Commercial Building Telecommunications Cabling Standard*

ANSI/TIA-568-C.2, *Balanced Twisted Pair Telecommunications Cabling and Components Standard*

IEC 61156-5, *Multicore and Symmetrical Pair/Quad Cables For Digital Communications – Part 5: Symmetrical Pair/Quad Cables With Transmission Characteristics Up To 600 MHz – Horizontal Floor Wiring – Sectional Specification*

IEEE 802.11-2007, *IEEE Standard for Information Technology—Telecommunications and Information Exchange Between Systems—Local and Metropolitan Area Networks—Specific Requirements—Part 11: Wireless LAN Medium Access Control*

IEEE 802.11n-2009, *IEEE Standard for Information Technology—Telecommunications and Information Exchange Between Systems—Local and Metropolitan Area Networks—Specific Requirements Part 11: Wireless LAN Medium Access Control (MAC) and Physical Layer (PHY) Specifications - Amendment 5: Enhancements for Higher Throughput*

IEEE Std. 1100-2005, *IEEE Recommended Practice for Powering and Grounding Electronic Equipment (IEEE Emerald Book)*

ISO/IEC 11801, *Information technology, Generic cabling for customer premises*

NECA/BICSI-607, *Telecommunications Bonding and Grounding Planning and Installation Methods for Commercial Buildings*

TIA-569-B, *Standard for Telecommunications Room Design*

TIA/EIA-606A, *Administration Standard for Commercial Telecommunication Infrastructure*

TIA/EIA-606A, *Addendum 1, Administration of Equipment Rooms and Data Center Computer Rooms*

TIA-607-B, *Generic Telecommunications Bonding and Grounding (Earthing) for Customer Premises*

TIA-942, *Telecommunications Infrastructure Standard for Data Centers*

Notes

About Panduit

Panduit is a world-class developer and provider of leading-edge solutions that help customers optimize the physical infrastructure through simplification, increased agility, and operational efficiency. Panduit's Unified Physical InfrastructureSM (UPI)-based solutions give organizations the capabilities to connect, manage, and automate communications, computing, power, control, and security systems for a smarter, unified business foundation. Panduit provides flexible, end-to-end solutions tailored by application and industry to drive performance, operational, and financial advantages. Panduit's global manufacturing, logistics, and e-commerce capabilities along with a global network of distribution partners help customers reduce supply chain risk. Strong technology relationships with industry leading systems vendors and an engaged partner ecosystem of consultants, integrators, and contractors together with its global staff and unmatched service and support make Panduit a valuable and trusted partner.

www.panduit.com · cs@panduit.com · 800-777-3300

Disclaimer

The information contained herein is intended as a guide for use by persons having technical skill at their own discretion and risk. Panduit disclaims any liability arising from any information contained herein or for the absence of same.

Notes

Feedback

Please use the [feedback form](#) to send comments and suggestions about this guide.



SMART BUSINESS ARCHITECTURE



Americas Headquarters
Cisco Systems, Inc.
San Jose, CA

Asia Pacific Headquarters
Cisco Systems (USA) Pte. Ltd.
Singapore

Europe Headquarters
Cisco Systems International BV Amsterdam,
The Netherlands

Cisco has more than 200 offices worldwide. Addresses, phone numbers, and fax numbers are listed on the Cisco Website at www.cisco.com/go/offices.

ALL DESIGNS, SPECIFICATIONS, STATEMENTS, INFORMATION, AND RECOMMENDATIONS (COLLECTIVELY, "DESIGNS") IN THIS MANUAL ARE PRESENTED "AS IS," WITH ALL FAULTS. CISCO AND ITS SUPPLIERS DISCLAIM ALL WARRANTIES, INCLUDING, WITHOUT LIMITATION, THE WARRANTY OF MERCHANTABILITY, FITNESS FOR A PARTICULAR PURPOSE AND NONINFRINGEMENT OR ARISING FROM A COURSE OF DEALING, USAGE, OR TRADE PRACTICE. IN NO EVENT SHALL CISCO OR ITS SUPPLIERS BE LIABLE FOR ANY INDIRECT, SPECIAL, CONSEQUENTIAL, OR INCIDENTAL DAMAGES, INCLUDING, WITHOUT LIMITATION, LOST PROFITS OR LOSS OR DAMAGE TO DATA ARISING OUT OF THE USE OR INABILITY TO USE THE DESIGNS, EVEN IF CISCO OR ITS SUPPLIERS HAVE BEEN ADVISED OF THE POSSIBILITY OF SUCH DAMAGES. THE DESIGNS ARE SUBJECT TO CHANGE WITHOUT NOTICE. USERS ARE SOLELY RESPONSIBLE FOR THEIR APPLICATION OF THE DESIGNS. THE DESIGNS DO NOT CONSTITUTE THE TECHNICAL OR OTHER PROFESSIONAL ADVICE OF CISCO, ITS SUPPLIERS OR PARTNERS. USERS SHOULD CONSULT THEIR OWN TECHNICAL ADVISORS BEFORE IMPLEMENTING THE DESIGNS. RESULTS MAY VARY DEPENDING ON FACTORS NOT TESTED BY CISCO.

Any Internet Protocol (IP) addresses used in this document are not intended to be actual addresses. Any examples, command display output, and figures included in the document are shown for illustrative purposes only. Any use of actual IP addresses in illustrative content is unintentional and coincidental.

© 2013 Cisco Systems, Inc. All rights reserved.

Cisco and the Cisco logo are trademarks or registered trademarks of Cisco and/or its affiliates in the U.S. and other countries. To view a list of Cisco trademarks, go to this URL: www.cisco.com/go/trademarks. Third-party trademarks mentioned are the property of their respective owners. The use of the word partner does not imply a partnership relationship between Cisco and any other company. (1110R)